



**Application Handbook
Complete Edition**

Bittner Audio Int. GmbH
<http://www.bittner-audio.com>

Version 2.5.0
November 20, 2023

Contents

1	General Information	6
1.1	Copyright & Acknowledgment	6
1.2	Disclaimer	6
1.3	Safety Instructions	6
1.4	Warranty Terms & Conditions	7
1.5	Packaging	8
1.6	Air Ventilation & Cooling Requirements	8
1.7	Installation in Rack	8
1.8	Power Connection	9
2	Technical Features	10
2.1	AC Power Switch	10
2.2	Backup Power	10
2.3	Remote Switching	11
2.3.1	Control Voltage	11
2.3.2	SXL II & RS-485	11
2.4	LED Indicators	12
2.4.1	Frontside	12
2.4.2	Backside	12
2.5	Level Control	13
2.5.1	Analog Level Control	13
2.5.2	Digital Level Control (with stop)	13
2.5.3	Digital Level Control (endless)	13
2.6	Audio Connections	14
2.6.1	PHOENIX	14
2.6.2	XLR /TRS Jack	14
2.7	Ground Lift	15
2.8	Loudspeaker Output Connectors	15
2.8.1	PHOENIX	16
2.8.2	SPEAKON	16
2.8.3	Binding Post	16
2.9	Operation Modes	16
2.9.1	Stereo Mode	17
2.9.2	Mono Mode	17
2.9.3	Parallel Mode	17
2.9.4	Bridged Operation	17
2.10	Alive Contacts	18
2.11	Multifunction Connector	18
2.11.1	Audio Inputs	19
2.11.2	Remote Power On	19
2.11.3	Power Supply Fault Indication	19
2.12	Data Port	19
2.12.1	I ² C	20
2.12.2	RS-485	20
2.13	Address-IDs	21
2.14	Noise Gate	22
2.15	EQ Card	22
2.16	Line Monitoring	23
3	Specifications of the Devices	24
3.1	BASIC Series	24
3.1.1	General Information	24
3.1.2	Features	24
3.1.3	Front & Rear View	25
3.2	XB Series	26
3.2.1	General Information	26
3.2.2	Features	26
3.2.3	Front & Rear View	27

3.2.4	Jumper and Fuses	28
3.3	XR Series	29
3.3.1	General Information	29
3.3.2	Features	29
3.3.3	Front & Rear View	30
3.3.4	Digital Signal Processor (DSP)	31
3.3.5	Control by RS-485 and PC	31
3.3.6	Emergency Paging Bus & Monitor Bus	32
3.4	4X Series	34
3.4.1	General Information	34
3.4.2	Features	34
3.4.3	Front & Rear View	35
3.4.4	Jumper and Fuses	36
3.5	4Xi/4Xe Series	37
3.5.1	General Information	37
3.5.2	Features	37
3.5.3	Front & Rear View 4Xi	38
3.5.4	Front & Rear View 4Xe	39
3.5.5	Fuses	40
3.5.6	Loudspeaker Output Connectors 4Xe	41
3.5.7	Clip Limiter	41
3.5.8	Dante™ Inputs	42
3.5.9	DIP Switches	42
3.6	4X DUAL Series	43
3.6.1	General Information	43
3.6.2	Features	43
3.6.3	Front & Rear View	44
3.6.4	Jumper and Fuses	45
3.7	8X Series	46
3.7.1	General Information	46
3.7.2	Features	46
3.7.3	Front & Rear View	47
3.7.4	Jumper and Fuses	48
3.8	XV Series	49
3.8.1	General Information	49
3.8.2	Features	49
3.8.3	Front & Rear View	50
3.8.4	Jumper and Fuses	51
3.9	XV DC Series	52
3.9.1	General Information	52
3.9.2	Features	52
3.9.3	Front & Rear View	53
3.9.4	DIP Switches	53
3.10	2DXV Series	55
3.10.1	General Information	55
3.10.2	Features	55
3.10.3	Front & Rear View	56
3.10.4	Sleep Mode	57
3.10.5	High Pass Filter	57
3.10.6	DIP Switches	57
3.11	4DXV Series	58
3.11.1	General Information	58
3.11.2	Features	58
3.11.3	Front & Rear View	59
3.12	XT Series	60
3.12.1	General Information	60
3.12.2	Connections	60
3.13	8XT Series	61
3.13.1	General Information	61
3.13.2	Front & Rear View	61

3.14 AX16 - Intelligent Amplifier Switch	62
3.14.1 General Information	62
3.14.2 Features	63
3.14.3 Front & Rear View	64
3.14.4 LED Indicators	65
3.14.5 Configuration	65
3.14.5.1 Switching Modes	66
3.14.5.2 Connected Amplifiers	66
3.14.5.3 Logic of Alive Contact	67
3.14.5.4 Control Modes	67
3.14.6 Connection of Amplifiers	67
3.14.6.1 Signal and Amplifier Inputs	67
3.14.6.2 Amplifier Outputs and Loudspeakers	68
3.14.6.3 Alive Contact of the Amplifiers	68
3.14.7 Data Port	69
3.14.8 Level Control	69
3.14.9 Alive and Active Contacts	69
3.14.10 Application Examples	71
3.14.10.1 Mode 7+1 with Alive Contacts	71
3.14.10.2 Mode 3+1 with SXL II and Alive Contacts	72
3.14.10.3 Mode 3+1 with 4 Channel Amplifiers and Alive Contacts	73
3.15 SXL II - Control Interface	74
3.15.1 General Information	74
3.15.2 Features	74
3.15.3 Front and Rear View	75
3.15.4 Starting Up	76
3.15.4.1 Network Connection	76
3.15.4.2 Connection of the Amplifiers and the AX16	77
3.15.4.3 Address IDs	77
3.15.4.4 Settings of Network Parameters	78
3.15.5 LED Indicators	78
3.15.6 Special Ports	79
3.15.6.1 Logical Inputs	79
3.15.6.2 Signalization Relays	80
3.15.6.3 General Purpose Relays	80
3.15.6.4 Signal Generator	80
3.15.7 Manual Operation	81
3.15.7.1 Menus & Parameters	81
3.15.7.2 Entry & Service Modes	82
3.15.7.3 Saving and Loading of Configurations	83
3.15.8 Web Interface	83
3.15.8.1 Status	84
3.15.8.2 Settings	85
3.15.8.3 DSP	85
3.15.8.4 Monitoring	86
3.15.8.5 Signalization	87
3.15.8.6 Configurations	88
3.15.8.7 AX16	89
3.15.8.8 Misc	90
3.15.8.9 Log	91
3.15.8.10 Home	91
3.15.9 Special Functions	92
3.15.9.1 Configuration Switching via the Logic Inputs	92
3.15.9.2 Error Matrix	93
3.15.9.3 Line Monitoring	93
3.15.9.4 Error Acknowledgment	94
3.15.9.5 Backup Switching	95
3.15.9.6 Permanent Backup of Operation Modes	96
3.15.10 Software & Files	97
3.15.10.1 FTP	97

3.15.10.2 Firmware	97
3.15.10.3 System Settings	98
3.15.10.4 Web Interface (Files)	98
3.15.10.5 Configurations	99
3.15.10.6 Logbook	99
3.15.11 Amplifier Functions	99
3.15.12 Error Codes	101
4 General Technical Information	102
4.1 Decibel	102
4.2 100 V	102
4.3 Measuring Amplifier Power	103
4.4 Heat Dissipation and Air Conditioning	104
4.5 Sound Pressure and Amplifier Power	104
4.6 Essentials	106
4.6.1 Load-to-Power Relation in 100 V Systems	106
4.6.2 Crest Factor	106
4.6.3 Resistance - Power	106
4.6.4 Voltages in dBV and dBu	106
4.6.5 “dB”-Relations	106
4.6.6 Conversion of THD to “dB below signal level”	107
4.6.7 Voltage to Power	107
5 Technical Data	108
6 Troubleshooting	111
List of Figures	112

1 General Information

1.1 Copyright & Acknowledgment

© Bittner Audio. All Rights Reserved.

Bittner Audio reserves specification privileges Information in this manual is subject to change without notice.

Congratulations and thank you for buying Bittner Audio.

1.2 Disclaimer

In no case shall Bittner Audio be liable for any special, incidental, or consequential damages to loudspeakers, amplifiers, or other equipment if such damages are based upon negligence during installation or operation. Such damages include, but are not limited to, loss of profits or any other loss of property of the purchaser. In case the contractual liability of Bittner Audio is excluded or limited, this also applies to the personal liability of employees, representatives, assistants and other auxiliary persons.

Should any part of the equipment show defects in materials and workmanship, including transport damage, the customer is asked to complain to Bittner Audio. Failure of complaint, however, has no consequences for your legal claims.

Bittner Audio points out that all specifications may be subject to change without notice and that liability for incorrect, incomplete or outdated information is excluded. This warranty does not affect your statutory rights.



Caution

International: Please contact your supplier for specific regional information, as rights and disclaimers may vary from country to country.

1.3 Safety Instructions



Caution

To reduce the risk of electrical shock, do not remove the cover. There are no user serviceable parts inside, refer all servicing to qualified personnel. Replace fuses only with same type. Avoid damaging the AC plug or cord. Damage may potentially cause a shock hazard. The apparatus should only be connected to an AC power supply of the correct voltage.



Caution

Never isolate the ground of the AC power cord (the non-fused earthed protective conductor) to eliminate hum-problems.

**Caution**

To reduce the risk of fire or electrical shock, do not expose this apparatus to rain or moisture and don't use it in damp areas or near water. The apparatus shall not be exposed to dripping or splashing water and no objects filled with liquids shall be placed on the apparatus.

**Caution**

The apparatus must be adapted slowly to extreme temperature changes. These extreme changes can cause inside moisture development that can cause failure and/or electrical shock.

**Caution**

The power fuses are located on the back panel of the apparatus and may be accessed from the outside. Use only the appropriate fuses as labeled.

**Caution**

Always use safe operating techniques! Incompetent and improper servicing will void the warranty.

**Caution**

Though all Bittner Audio devices are quite simple to operate and are covered by a solid steel chassis, improper use may be dangerous. Some of the units can put out very high voltages and a sizable current at frequencies up to 30 kHz. Any connections to the speaker terminals marked with a "lightning symbol" shall be made only by an instructed person.



Figure 1.1: Lightning Symbol

1.4 Warranty Terms & Conditions

Bittner Audio warrants this product to be free from defects in materials and workmanship.

Should any part of this equipment be defective, the Manufacturer agrees to repair or replace any defective part free of charge (except transportation charges) for a period of three years from the date of the original purchase.

Warranty service is effective and available to the original purchaser only.

To obtain service under this warranty, the product must, on discovery of the defect, be properly packed and shipped to the nearest Bittner Audio dealer. The party requesting service must provide proof of original ownership and date of purchase of the product.

If the warranty is valid, Bittner Audio will, without charge for parts or labor, either repair or replace the defective parts. Without a valid warranty, the entire cost of the repair is the responsibility of the product's owner.

The warranty does not cover defects or repairs needed as a result of:

1. Damage caused by abuse, accident, or negligence.
2. Damage caused by any tampering, alteration, or modification of the product or its components.
3. Damage caused by failure to maintain and operate the product in strict accordance to the written instruction of this operating manual.
4. Damage caused by repairs or attempted repairs by unauthorized persons.
5. Damage caused by fire, water and other natural events.
6. Damage caused by operation on improper voltages.

1.5 Packaging

Upon unpacking, please inspect the product. If you find any damage, notify your supplier immediately. Be sure to save the carton and all packing materials in case you have to send the product to the supplier.

Please use only the original factory packing. If the shipment carton is unavailable, contact Bittner Audio International GmbH (www.bittner-audio.com) to obtain a replacement.

1.6 Air Ventilation & Cooling Requirements

The devices are equipped with a forced air-cooling system with variable speed and temperature controlled fans to guarantee low operating temperature and minimal ventilation noise. The air flow takes place from the rear to the front of the amplifier. The air-pulling fans are installed on the back side of the unit. The air flow is always from the front to the rear side.

In case a heat sink becomes too hot, the temperature sensor opens the respective output relay, disconnecting the output load from the particular channel. In case the power transformer gets overheated, a different sensor causes the output relays on all channels to open and to interrupt the outputs. After cooling down to an appropriate operating temperature level the relay contacts are closed again automatically.

It is important to have adequate air ventilation space behind the amplifier to allow a proper air flow. In case the amplifier is mounted inside a closed rack, do not cover the front of the rack with doors. If using racks with a closed backside, use fans on the rear rack panel. Bittner Audio recommends one open rack space for every 2 mounted power amplifiers.

1.7 Installation in Rack

All devices will mount in standard 19-inch racks having sufficient depth and should be mounted with four standard rack bolts. To avoid the deformation of the chassis it is recommended to mount heavy units on horizontal brackets.

Please ensure a sufficient airflow. In the case, closed racks are being used rack-fans should be used. For larger installations one open rack space (1 RU) for every 2 mounted power amplifiers should be provided.

1.8 Power Connection

The power amplifier must be connected only with the attached three-wire safety power cord with protective conductor (non-fused earthed conductor).

This amplifier is made for use with the mains voltage labeled on the back of the amplifier only. Check the label on the back panel of the amplifier for the appropriate voltage. Make sure the voltage of your mains outlet is correct. The power voltage is factory set as labeled on the back panel and cannot be changed afterwards. Damage caused by connecting the amplifier to improper AC voltage voids the warranty.



Caution

Never isolate the ground of the AC power cords (the non-fused earthed protective conductor) to eliminate hum-problems.

Always turn off and disconnect the amplifier from the mains voltage before making any audio connections. As a precaution, turn the audio attenuators on the front panel down during powering up.

The power fuses are located on the back panel of the amplifier and can be accessed from the outside. Use only the appropriate fuses as labeled.

After properly mounting and connecting the AC cord and the audio connections, the unit can be switched on.

2 Technical Features

2.1 AC Power Switch

If the remote switching option is not being used, the device must be switched on and off with the main power switch.



Caution

To switch off the amplifier unit it is mandatory to disconnect it from any power supply by unplugging the power cord and the backup power cord (where applicable)

To use the remote power switching option, the main power switch must be set as follows:

Amplifier	Position
XB 400/800	Off
XB 1600/2200	On
XR DSP	Off
XV	Off
XV DC	On
2DXV	On
4DXV	On
4X	On
4Xi	On
4Xe	On
4X DUAL	Off
8X	Off

2.2 Backup Power

The amplifiers of the the XV DC, 2DXV and 4DXV Series are equipped with an input for a 24 V backup power supply. In case of a loss of the mains supply the amplifier will switch automatically to the 24 Volt input. The DC current will be limited for safety reasons.



Caution

The 24 Volt DC supply input must be protected by an external fuse.



Figure 2.1: Backup Power Connector

2.3 Remote Switching

2.3.1 Control Voltage

In this mode the PHOENIX terminal block (see picture) is used to remotely power up the amplifier with a control voltage (12 VDC 80mA). Terminal *IN +/-12V* is used as the control voltage input. Feeding these terminals with the control voltage will switch the amplifier on.

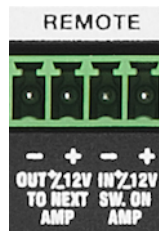

Figure 2.2: Remote Switching PHOENIX Connector

After a delay of one second the control voltage will appear on the terminals labeled *OUT +/-12V* of the PHOENIX terminal block. The *OUT* terminals may be connected to the terminals *IN* of the next amplifier for sequential power switching.

Up to 16 units may be daisy-chained this way. The control voltage must be applied until the last amplifier in the daisy-chain is being switched on. Each amplifiers draws 80mA.

By supplying the inverted DC control voltage to terminal *IN*, all connected amplifiers will be switched off.

Pin	Function
IN+	Amplifier Switching POSITIVE terminal
IN-	Amplifier Switching NEGATIVE terminal
OUT+	Control Voltage output for sequential switching POSITIVE terminal
OUT-	Control Voltage output for sequential switching NEGATIVE terminal



Caution

To use the remote power on, the mains power switch needs to be switched On or Off, depending on the amplifier model (refer to [section 2.1](#)).



Caution

A second *Remote Power On* through the *Multifunction Connector* (refer to [section 2.11](#)) has a higher priority. Therefore it is not possible to use both options at the same time.

2.3.2 SXL II & RS-485

If the device is connected to a Bittner Audio SXL II or via the RS-485 interface to a PC (XR only), the unit can be remotely switched on and off at any time.

2.4 LED Indicators

2.4.1 Frontside

The amplifiers are equipped with 4 LEDs for each amplifier channel:

LED	Color	Function
POWER	green	The amplifier is powered up.
CLIP	red	The input is overloaded. The LED starts illuminating as soon as the signal is 0.5 dB under full power.
SIGNAL	green	The signal reaches the output stage of the amplifier.
PROTECT	red	This LED will light up as soon a protection circuit has been activated or if one of the output relays has been activated. When the amplifier is switched on, this LED will light up for approximately 1.5 seconds.

The amplifiers of the XB Series feature an Overheat LED. If the amplifier reaches an operational temperature of 90° Celsius the LED will light up.

The amplifiers of the XV DC, 2DXV and 4DXV Series are equipped with 2 additional LEDs for the supply voltages:

LED	Color	Function
AC POWER	green	Mains is present
DC POWER	green	Backup Power +24V is present

The amplifiers of the 2DXV Series are equipped with additional LEDs:

LED	Color	Function
SLEEP ON	green	Sleep mode of a channel is active
MONO MODE	green	Amplifier operates in mono mode

2.4.2 Backside

Amplifiers with an incorporated micro controller use an LED to indicate its operational status:

- slow blinking (about 1x/sec): All channels are OK
- fast blinking (about 3x/sec): Either the power supply failed or at least one of channels is in protect or the 24 V backup power is not connected



Figure 2.3: Amp Status



Caution

After a power on of the amplifier the LED is blinking fast (up to 3 sec.) until all internal supply voltages have reached their correct levels.

2.5 Level Control

2.5.1 Analog Level Control

The amplifiers are equipped with two analog level control knobs, which are setting the level of the amplifier. The adjusting range is -90dB to 0dB. The 16 different settings of the switch are as follows:

-90, -60, -30, -24, -21, -18, -15, -13, -11, -9, -7, -5, -4, -3, -1 und 0 dB.



Figure 2.4: Analog Level Controls

2.5.2 Digital Level Control (with stop)

The devices are equipped with a rotary switch per channel of the amplifier, which is setting the level of the amplifier. The adjusting range is -90dB to 0dB. The 16 different settings of the digital switch are as follows:

-90, -78, -66, -54, -42, -30, -24, -18, -15, -12, -9, -6, -3, -2, -1 and 0 dB.



Figure 2.5: Digital Level Controls (with stop)



Caution

Please keep in mind that the position of the rotary control will be detected by a microcontroller which will then set the according level of the amplifier when it's switched on.

The XR series is an exception: The last set level is stored in the DSP. After powering up, the amplifier will be set to this level. Furthermore the stored level will be ignored if the rotary control is being set to -90dB.

2.5.3 Digital Level Control (endless)

The devices are equipped with a rotary switch per channel of the amplifier, which is setting the level of the amplifier. The adjusting range is -90dB to 0dB. The 16 different settings of the digital switch are as follows:

-90, -78, -66, -54, -42, -30, -24, -18, -15, -12, -9, -6, -3, -2, -1 and 0 dB.



Figure 2.6: Digital Level Controls (endless)



Caution

There is no stopping position for the rotary control. If the switch is turned beyond -90dB setting to the 0dB setting, the level will not jump from full attenuation to full power but remain in the -90dB position.

This feature will prevent the destruction of connected equipment and/or injury of persons. As the rotary direction is being sensed, it is necessary to turn the switch clockwise again to set the amplifier to higher levels.

Please keep in mind that the position of the rotary control will be detected by a microcontroller which will then set the according level of the amplifier.

If the amplifier was operated at full attenuation before turning it off with the rotary control accidentally set to 0dB it will start up with full power!

In the opposite case it will start up fully attenuated at -90dB and you won't hear any audio!

2.6 Audio Connections

The amplifiers may be operated with unbalanced or balanced lines. For optimum performance use balanced lines whenever possible. The driving device should be equipped with a balanced output.

Nevertheless, short cables inside a rack are not that critical. In these cases unbalanced cables may be used.



Caution

Always turn off the amplifier before making any connections. As an additional precaution by switching the amplifier on for the first time, turn the audio attenuators down during powering up.

2.6.1 PHOENIX

The Phoenix audio connectors are electronically balanced. Each input contains three pins: Signal (+), Signal (-) and Shield. Depending on the model more than one channel might be combined on the PHOENIX connector.

2.6.2 XLR /TRS Jack

The amplifiers series BASIC, 4Xe and XR are equipped with two combined input connectors. They can be used for regular XLR connectors and for 6.3 mm TRS jacks, mounted in the same connector chassis. The audio inputs of the BASIC and XR amplifiers are electronically balanced.

Standard pinout for the XLR connectors:

1 - Ground, Shield | 2 - Signal (+) | 3 - Signal (-)

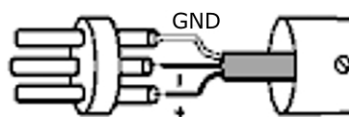

Figure 2.7: XLR Connector

Standard pinout for the 6.3 mm TRS-jack:

Tip - Signal (+) | Ring - Signal (-) | Sleeve - Ground, Shield





Figure 2.8: TRS Jack

2.7 Ground Lift

The chassis ground of the amplifier is connected with the ground of the AC power cord (the non-fused earthed protective conductor). Therefore, if several devices are connected in a signal chain a ground loop may be created. This ground loop will cause a compensating current to travel on the shields of the audio cables causing hum-problems.

The amplifiers series BASIC, XB and XR are equipped with a *Ground Lift* switch on the back side of the unit.

It has three settings:

Character	Signification/Meaning
	Signal ground (Audio) is separated from chassis ground
	Signal ground (Audio) is connected to chassis ground
	Signal ground (Audio) is connected to chassis ground via a 10 ohms resistor

Setting 1 and 3 will remove hum in most cases.



Caution

Although *Ground Lift* is a common and proven method, proper cabling and grounding should avoid hum in the first place.



Caution

Isolating the ground of the AC power cord is technically different and eliminates the protective earth connection. Therefore, NEVER isolate the ground of the AC power as this may pose a serious danger to your life.

2.8 Loudspeaker Output Connectors

Use heavy gauge wire. It is advisable to use thicker cables to bridge greater distances between amplifier and speakers. This will minimize power losses across the wire and improve the damping factor.

Please note: Wire thickness specifications (gauges) get larger as the wire gets thinner. So a 14-gauge wire is thicker than 18-gauge wire.

2.8.1 PHOENIX

The Phoenix audio connectors contain two pins per channel: Signal (+) and Signal (-). Depending on the model more than one channel might be combined on the PHOENIX connector.



Caution

OUTPUT TERMINAL SAFETY WARNINGS:

The removable PHOENIX terminal block must be fastened to the amplifier's output connector by screws.

Do not touch output terminals while amplifier power is on. Make all connections with amplifier turned off. Risk of hazardous energy!

2.8.2 SPEAKON

Speaker cables may be connected to the 4 pin NEUTRIK SPEAKON connectors.

Pin-out SPEAKON connector NL4FC for channel 1 and 2:

Pin	Function
1+	Output (+)
1-	Output (-)
2+	n/c
2-	n/c

The PHOENIX connectors are connected in parallel to channel 1 and 2 of the SPEAKON connectors. It is possible to use both connections at the same time (to parallel several loudspeakers). In this case the polarity of the speakers has to be the same. It is also important not to go below the minimum load impedance of the amplifier.

2.8.3 Binding Post

The Binding Posts contain two pins per channel: Signal (+) and Signal (-). Every two channels are combined on one block.



Caution

OUTPUT TERMINAL SAFETY WARNING! Do not touch output terminals while amplifier power is on. Make all connections with amplifier turned off. Risk of hazardous energy!

2.9 Operation Modes

On the rear of the amplifier different operation modes can be selected on a DIP-Switch panel.

The amplifier must be re-powered before the mode change is activated.



Caution

If the amplifier doesn't have a switch, the operation mode has to be set up by the wiring of the inputs and loudspeaker outputs.

2.9.1 Stereo Mode

For stereo operation set the mode select switch to STEREO (factory default). Models without a switch are automatically working in stereo mode. Please connect the input signals for both channels to the input connectors of CH1 AND CH2.

The input signals are available on the corresponding output channel.

2.9.2 Mono Mode

The amplifiers of the 2DXV series can be set to operate in mono mode. This results in one channel which supplies double the output power. To activate it the corresponding DIP switch at the back of the amplifier needs to be set to ON (refer to [section 3.10.6](#)).

In mono mode only the input and output of channel 1 are active.

2.9.3 Parallel Mode

In PARALLEL mode both amplifier channels get the same input signal.

In case of a mode switch set it to PARALLEL. Connect the input signal to input CH1 (Channel 2 is disabled). The input signal of channel 1 is available on both output channels.

In case of no mode switch simply connect both inputs to the same audio source.

2.9.4 Bridged Operation

Both amplifiers may be bridged together to create a powerful single-channel mono amplifier.



Caution

This operation mode is not available for the amplifiers with 100V outputs.

In case of a mode switch it needs to be set to the BRIDGE position. Connect the input signal to CH1 (Channel 2 is not active). The amplified signal is now available on both positive (+) pins of the output terminals.

Even in case of no mode switch each pair of channels can operate in bridge mode. This is achieved by using a reversed polarity of the channels to each other. The second channel gets the same input signal, but the plus and minus pins are connected the other way round.

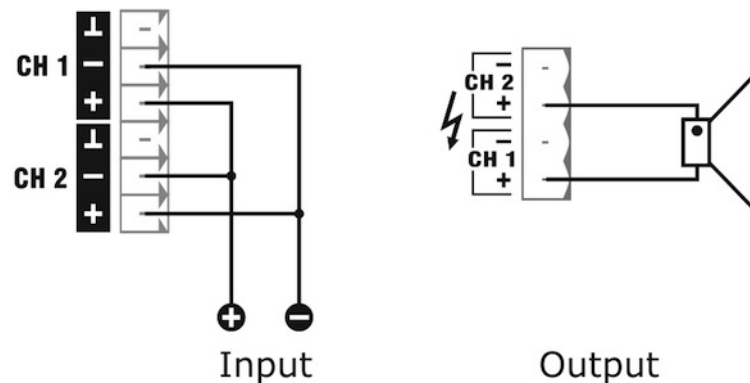

Figure 2.9: Wiring in Bridge Mode with no mode switch

**Caution**

Both potentiometers remain active and should be set to the same value.

2.10 Alive Contacts

Bittner Audio amplifiers (with the exception of the BASIC and 4X DUAL Series), the Switching Unit AX16 and the SXL II Control Interface are equipped with an *Alive contact*.

The GPI contact is located on the rear panel of the amplifier and indicates the operational condition of the amplifier. It is normally designed as a 3-pole contact closure that may be used in the open or the closed mode. In case of a 2-pole contact (normally open) it works like pin 2+3 of the 3-pole contact.



Figure 2.10: Alive Contact

State	Position	Funktion
Alive Contact active	pins 2+3 connected	indicates that the amplifier is working in normal conditions
Alive Contact inactive	pins 1+2 connected	indicates that the amplifier is not working properly: it is shut down by the protection circuit, overheated etc. or generally switched off

The amplifiers of the 2DXV Series are equipped with 2 additional alive contacts (2-pole contact, normally open) for the mains and backup power.

State	Position	Funktion
Alive Contact active	closed	Power is applied
Alive Contact inactive	open	Power is not applied

Contact closures are the simplest form of remote system monitoring of the amplifier without establishing a remote control network and provide easy system surveillance. Contacts may also be integrated into a media control network as a GPI contact closure to trigger other control functions, i.e. backup amplifier (spare amplifier) switching, if required.

2.11 Multifunction Connector

The amplifiers series XV DC and 2DXV use a RJ-45 jack as a multifunction connector.

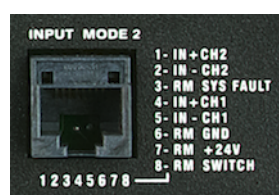

Figure 2.11: Multifunction Connector

2.11.1 Audio Inputs

The audio inputs are electronically balanced. Both inputs consist of the 2 Pins *IN+* and *IN-*. Shield is not connected.

2.11.2 Remote Power On

To enable remote control, an auxiliary voltage of 24VDC (max. 20mA) has to be applied to the Pins *RM GND* and *RM +24V*. A continuous connection of the control input *RM SWITCH* to *GND* will turn the amplifier on, a continuous connection to *RM +24V* will turn it off.

Pin	Label	Function
6	RM GND	Aux Voltage Gnd
7	RM +24V	Aux Voltage +24V
8	RM SWITCH	Input Control Voltage



Caution

As soon as the auxiliary voltage of 24VDC is connected the other *Remote Power On* option through the PHOENIX connector (refer to [section 2.3.1](#)) is disabled.

2.11.3 Power Supply Fault Indication

The fault indication output *RM SYS FAULT* indicates the loss of the supply voltage.

RM SYS FAULT can show 3 conditions:

Condition	Status
+24V	No Error
0V	AC fail, DC ok
Alternating 3s pulse between +24V and 0V	AC ok, DC fail

2.12 Data Port

Bittner Audio amplifiers Series XR, 4X, 4Xi, 4Xe, 4X DUAL, 8X and the switching unit AX16 are equipped with the SXL II data port, which allows the monitoring and control of the amplifier by an SXL II Control Interface (refer to SXL II ([section 3.15](#))).

Device	Data Port
AX16	I ² C
4X	RS-485
4Xi	RS-485
4Xe	RS-485
4X DUAL	I ² C
8X	I ² C
XR	I ² C und RS-485

Up to 16 amplifier channels may be connected to the SXL II. The 16 amplifier channels may be freely combined of 2-, 4- and 8-channel amplifiers.

After the amplifier has been connected to the SXL II, it will be automatically recognized. The Link LED on the SXL II front panel indicates *ON*. Communication with the SXL II unit is indicated by the fast blinking green (TX) LED on the amplifier's rear panel.

For more details please refer to SXL II ([section 3.15](#)).

2.12.1 I²C



Figure 2.12: I²C Data Port

Pin	Function
1	SDA I ² C Data
2	SCL I ² C Clock
3, 11	+12V Supply
4, 6, 8, 9, 10, 12, 14	Ground Supply
5, 7, 13, 15	n/c



Caution

The 12V supply drives the Data-Interface of an amplifier in case the mains supplies have been turned off or interrupted.

2.12.2 RS-485

The RS-485 interface on the XR Series amplifiers is a half-duplex transceiver with one single bus (2-wire) for transmitting and receiving data on the same bus.

DATA+ is pulled via 10k resistor to +5V volts and DATA- is pushed to RS-485 GND via 10k in idle state.



Figure 2.13: RS-485 Data Port

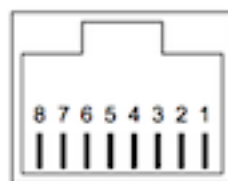

Figure 2.14: RS-485 Connector

Pin	Function
3, 6	DATA+
4, 5	DATA-
1, 8	Ground
2, 7	n/c

Amplifiers with a RS-485 interface are equipped with two parallel ports, PORT1 and PORT2 (RJ-45). To establish a RS-485 bus topology, PORT1 should be used as an input and PORT2 as the output to the next amplifier in the chain.

Two LED indicators are active while receiving data (red=RX) and transmitting data (green=TX) over RS-485.

2.13 Address-IDs

To connect the amplifiers to the SXL all amplifiers must have a unique address. The address is selected on the DIP switch at the rear panel of the amplifier.

Multichannel amplifiers receive several consecutive IDs. Every amplifier module consisting of two channels gets one ID.



Caution

After an address change the amplifier must be disconnected from the data port connection and re-powered to activate the changes!

DIP Switch settings for 2-Channel-Amplifiers:

Address	SW1	SW2	SW3
ID 1	ON	ON	ON
ID 2	OFF	ON	ON
ID 3	ON	OFF	ON
ID 4	OFF	OFF	ON
ID 5	ON	ON	OFF
ID 6	OFF	ON	OFF
ID 7	ON	OFF	OFF
ID 8	OFF	OFF	OFF

DIP Switch settings for 4-Channel-Amplifiers:

Address	SW1	SW2
ID 1+2	OFF	OFF
ID 3+4	ON	OFF
ID 5+6	OFF	ON
ID 7+8	ON	ON

DIP Switch settings for 8-Channel-Amplifiers:

Address	SW1	SW2
ID 1+2+3+4	OFF	OFF
ID 5+6+7+8	ON	ON

2.14 Noise Gate

The amplifier of the 4X, 4X DUAL and 8X series are equipped with individual noise gates per channel. The noise gates are activated by the DIP switch on the rear panel of the amplifier. The threshold can be selected by the DIP switch settings.

Parameter	Value
Attack Time	400 μ s
Release Time	4 s
Damping	90 dBu
DIP SW3	ON = Noise Gate ON

| OFF = Noise Gate OFF

DIP SW4 | ON = -54 dBu Threshold

| OFF = -48 dBu Threshold

2.15 EQ Card

The amplifiers of the XB, XV, 4X, 4X DUAL and 8X series are equipped with a plug-in slot to accommodate a Bose EQ card per channel. They are located on the power modules of the amplifier. To install the EQ cards, the cover of the amplifier needs to be opened.

To activate the EQ card, jumpers on the main board (power board) need to be set correctly:

EQ Card installed: Jumper removed

EQ Card not installed: Jumper set

In addition the High Pass filter of the EQ card can be used:

High Pass Filter activated: Jumper removed

High Pass Filter not activated: Jumper set

The following table indicates the jumper number dedicated to a function or amplifier channel.

Series	Channel	EQ Card	High Pass Filter	Reference
XB	1	JP1	—	section 3.2.4
	2	JP101	—	
XV	1	JP1	—	section 3.8.4
	2	JP101	—	
4X	1	JP2	JP3	section 3.4.4
	2	JP9	JP10	
	3	JP2	JP3	
	4	JP9	JP10	
4X DUAL	1	JP2	JP3	section 3.6.4
	2	JP9	JP10	
	3	JP2	JP3	
	4	JP9	JP10	
8X	1	JP5	JP3	section 3.7.4
	2	JP7	JP14	
	3	JP6	JP4	
	4	JP8	JP12	
	5	JP5	JP3	
	6	JP7	JP14	
	7	JP6	JP4	
	8	JP8	JP12	



Caution

Please make sure that the EQ card is installed correctly. Bittner Audio is not responsible for damages resulting from improper installation of the EQ card.

2.16 Line Monitoring

In combination with a SXL II the amplifiers of the XR, 4X, 4Xi and 4Xe series may be used to monitor the impedance of the connected loudspeaker lines.

For more details please refer to [section 3.15.9.3](#).

3 Specifications of the Devices

3.1 BASIC Series

3.1.1 General Information

No Compromises!

Meeting the tightest budgets and professional requirements in reliability, flexibility, and sound. Alone or in combination with other products of the Bittner portfolio.

First-rate workmanship and the use of high-class components made the BASIC Series a standard and the choice of many contractors worldwide.

3.1.2 Features

- High Tech SMT design
- Excellent sound and superior impulse response
- Clip Limiter
- Protection Circuits: DC, LF, HF, Thermal, Short Circuit, Current Limiter
- XLR/TSR Inputs
- SPEAKON and Binding Posts outputs
- Toroidal transformers
- LED Indicators for SIGNAL, CLIP, PROTECT, POWER
- Temperature controlled, variable speed, low noise fans
- Detent potentiometers
- Stereo/Bridged/Parallel Mode
- Ground Lift
- Robust Steel Chassis

3.1.3 Front & Rear View

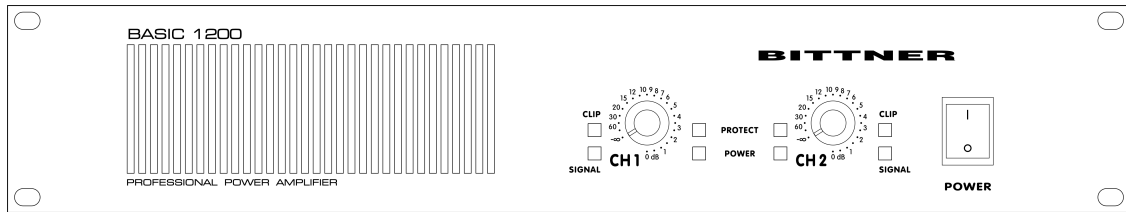

Figure 3.1: BASIC Series - Front View

Connectors and Controls of the front panel	Reference
Mains Power Switch	section 2.1
Volume Controls	section 2.5.1

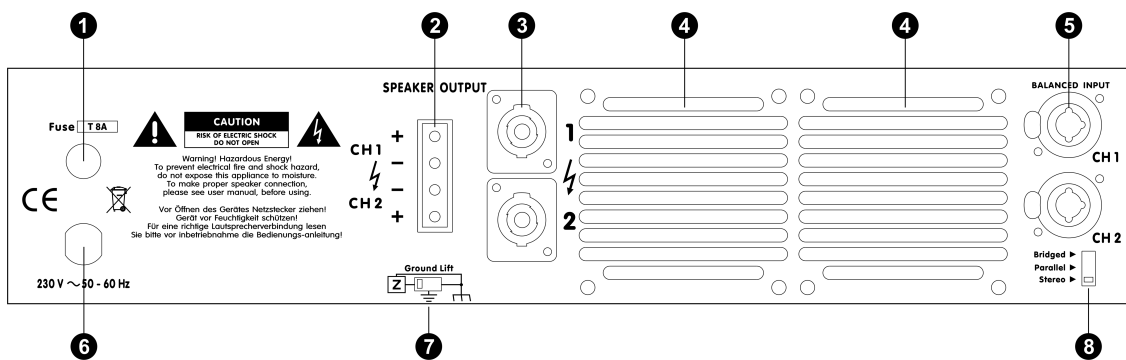

Figure 3.2: BASIC Series - Rear View

Connectors and Controls of the rear panel	Reference
1 Fuse Mains Supply	
2 Loudspeaker Outputs Binding Post	section 2.8.3
3 Loudspeaker Outputs SPEAKON	section 2.8.2
4 Fan	
5 Audio Inputs XLR/TRS	section 2.6.2
6 Power Cord	
7 Ground Lift	section 2.7
8 Operation Mode	section 2.9

3.2 XB Series



Caution

Production of the model XB400 stopped in October 2023. The information listed here on this model is for reference purposes only.

3.2.1 General Information

Straight. Powerful!

Versatile, dynamic, stable. For a maximum in operational safety and quality.

Sequential remote power On/Off and an alive contact to provide permanent evaluation of its operational condition. The XB solves all jobs.

One-for-All!

3.2.2 Features

- Perfect for fixed installations
- High Tech SMT Design
- Excellent sound and superior impulse response
- Protection Circuits: DC, LF, HF, Thermal, Short Circuit, Current Limiter
- PHOENIX input and output connectors
- XB 1600/2500 with High-End Switched Power Supply
- XB 400/800 with High-End Toroidal Power Transformer
- Temperature controlled, variable speed low noise fans
- Analog Volume Controls on the rear panel
- EQ card slot ([section 2.15](#))
- LED Indicators for POWER, SIGNAL, CLIP, PROTECT and OVERHEAT ([section 2.4.1](#))
- Stereo/Bridged/Parallel Mode
- Softstart
- Sequential remote power On/Off
- Alive Contact
- Ground Lift

3.2.3 Front & Rear View

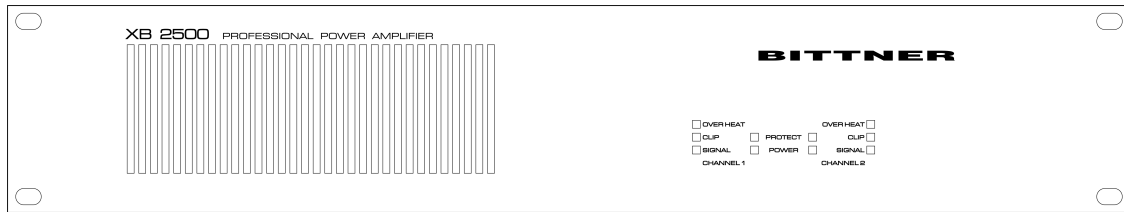

Figure 3.3: XB Series - Front View

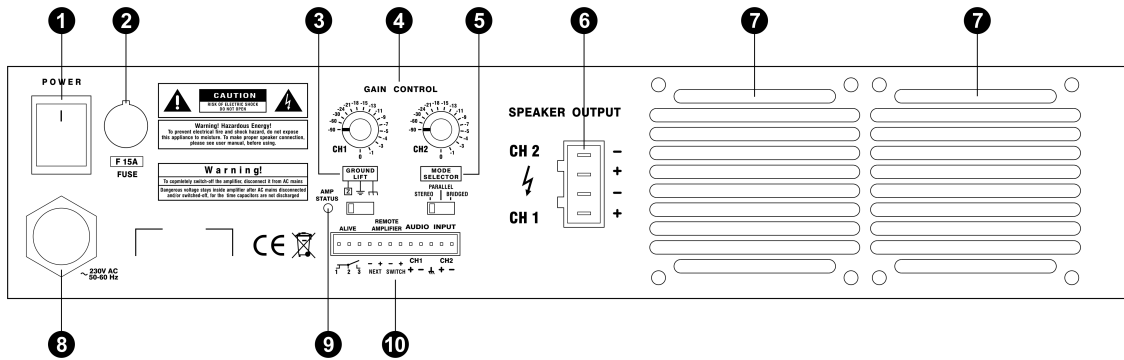

Figure 3.4: XB Series - Rear View

Connectors and Controls of the rear panel	Reference
1 Mains Power Switch	section 2.1
2 Fuse Mains Supply	
3 Ground Lift	section 2.7
4 Volume Controls	section 2.5.1
5 Operation Mode	section 2.9
6 Loudspeaker Outputs	section 2.8.1
7 Fan	
8 Pluggable Mains Cord	
9 Status LED	section 2.4.2
10 Alive Contact	section 2.10
10 Remote Power On/Off	section 2.3.1
10 Audio Inputs	section 2.6.1

3.2.4 Jumper and Fuses

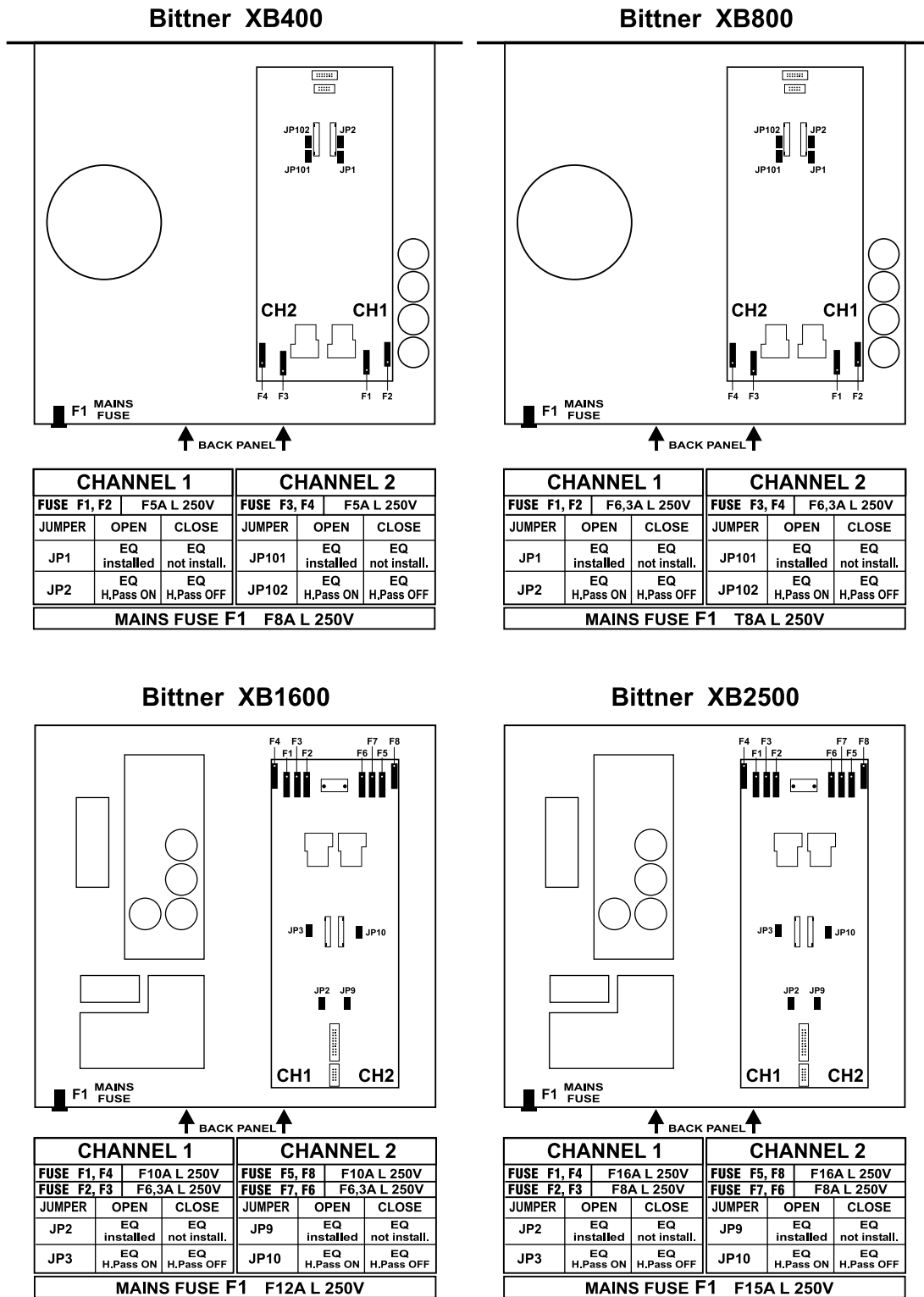

Figure 3.5: XB Series - Jumper and Fuses

3.3 XR Series

3.3.1 General Information

New Horizons.

A lightweight power horse. Combined with sophisticated digital signal processing. For all types of loudspeakers and venues. Line monitoring and extensive control included.

The integrated powerful digital signal processor (DSP) and controller allows for a troublefree and easy adjustment to any acoustical environment.

With wear-free digital potentiometers, sequential remote power on, alive contacts for easy supervision, computer controlled monitoring.

A new definition of powerful intelligence.

3.3.2 Features

- Premium DSP with extensive functions
- Impedance monitoring ([section 2.16](#))
- High-End Switched Power Supply with Power Factor Correction
- Excellent sound and superior impulse response
- Protection Circuits: DC, LF, HF, Thermal, Short Circuit, Current Limiter
- PHOENIX inputs and outputs
- XLR/TSR Inputs
- SPEAKON outputs
- LED Indicators for SIGNAL, CLIP, PROTECT, POWER
- SXL II data ports (I²C, RS-485)
- Alive contact
- Paging Input
- Monitor output
- Sequential remote power On/Off
- Temperature controlled, variable speed low noise fans
- Digital wear-free Volume Controls
- Stereo/Bridged/Parallel Mode
- Softstart
- High Tech SMT Design
- Perfect Weight-to-Power ratio

3.3.3 Front & Rear View

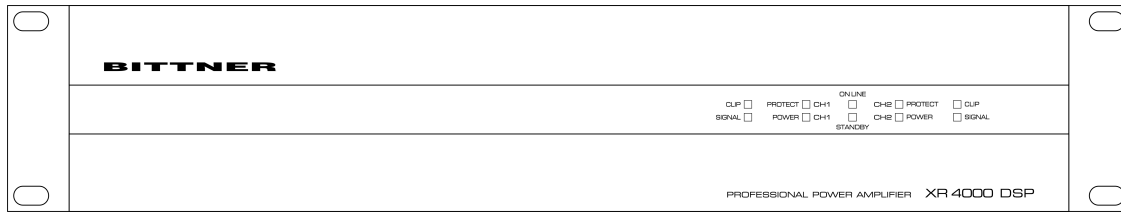

Figure 3.6: XR Series - Front View

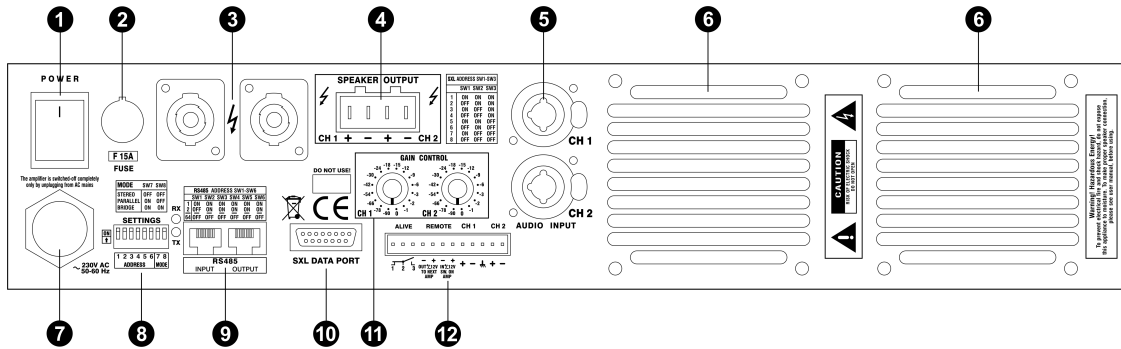

Figure 3.7: XR Series - Rear View

Connectors and Controls of the rear panel	Reference
1 Mains Power Switch	section 2.1
2 Fuse mains Supply	
3 Loudspeaker Outputs SPEAKON	section 2.8.2
4 Loudspeaker Outputs PHOENIX	section 2.8.1
5 Audio Inputs XLR/TRS	section 2.6.2
6 Fan	
7 Power Cord	
8 Address-ID I²C	section 2.13
8 Address-ID RS-485	section 3.3.5
8 Operation Mode	section 2.9
9 RS-485 Data Port	section 2.12.2
10 I²C Data Port	section 2.12.1
11 Volume Controls	section 2.5.2
12 Alive Contact	section 2.10
12 Remote Power On/Off	section 2.3.1
12 Audio Inputs PHOENIX	section 2.6.1

3.3.4 Digital Signal Processor (DSP)

The XR amplifiers are equipped with an internal DSP processor for extended functionality:

- Level Control
- Input routing of the two amplifier channels
- 10-Band Equalizer
- Dynamics (Limiter/Compressor/Gate)
- Delay
- Cross-Over
- Signal generator
- Up to 100 presets

The internal DSP can be controlled by:

- the Bittner Audio SXL II control interface
- the DSP software installed on a computer, connected via RS-485

3.3.5 Control by RS-485 and PC

The DSP can also be controlled via the RS-485 port on the rear panel of the amplifier. To establish control, the appropriate software must be installed on a computer. The RS-485 interface was chosen to allow for direct control from a computer or media controller without the use of an SXL control interface.

Although RS-485 offers many advantages, i.e. long distances, a data bus, it is not a standard interface on a standard computer.



Caution

To allow for easy connection of a laptop to a RS-485 network, Bittner Audio offers the USB to RS-485 converter NA-1.



Figure 3.8: NA-1

In the RS-485 control mode the amplifier is identified by its address. Use the DIP SWITCH ADDRESS 1–6 settings to set the RS-485 node address from 01 to 64:

Examples:

Address 01: ON ON ON ON ON ON
 Address 02: OFF ON ON ON ON ON
 ...
 Address 64: OFF OFF OFF OFF OFF OFF



Caution

The amplifier must be re-powered before the address change is activated!

The input/output values of all amplifier channels are being monitored. The following reduced set of values and conditions is available via the RS-485 interface:

- Heatsink temperature
- Protect
- Clip
- Load impedance (reliable values only between -30dB under maximum power and maximum output level)

3.3.6 Emergency Paging Bus & Monitor Bus

This input can be switched into the audio path as a priority signal, e.g. for emergency announcements. It's available through the data port connector and is activated by a relay per channel.

Pin	Function
4	Paging (+)
12	Paging (-)



Caution

This feature is only available in connection with an SXL II.

This additional output allows to listen to the audio signal directly at the loudspeaker output of the amplifier. The Monitor Bus is available through the data port connector at line level. It is activated by a relay per channel.

Pin	Function
5	MonitorB (+)
7	MonitorA (+)
13	MonitorB (-)
15	MonitorA (-)



Caution

This feature is only available in connection with an SXL II.

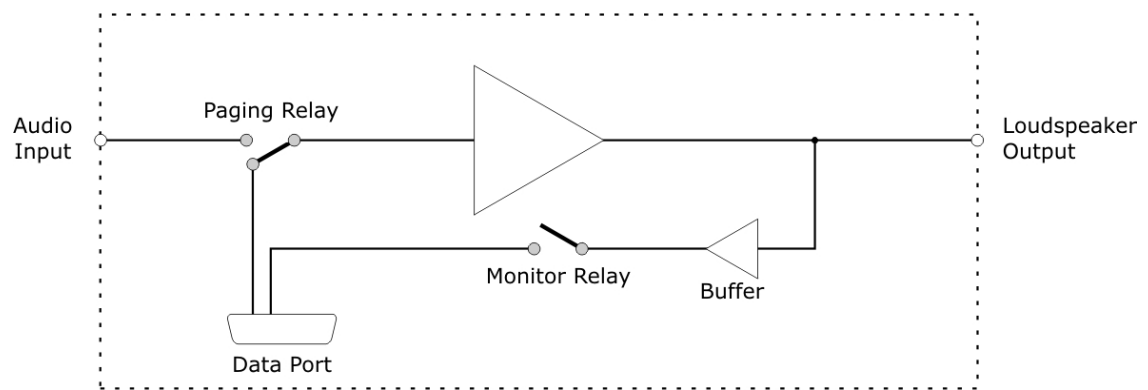

Figure 3.9: XR Series - Emergency Paging Bus and Monitor Bus

3.4 4X Series



Caution

Production of the 4X Series stopped in November 2014. Its successor is the 4Xi/4Xe Series. The information listed here is for reference purposes only.

3.4.1 General Information

Power. Intelligence. Control.

Unlimited and uncompromising. Superior sound. Including line monitoring.

Switched supplies? Naturally! Peak performance won't come easy! Wear-free digital potentiometers, sequential remote power on, alive contacts for every channel pair, computer control, detachable connectors.

Sometimes answers come easy.

3.4.2 Features

- Up to 4x 1400 W in only 2 RU
- 2 separate stereo amplifiers
- Line monitoring ([section 2.16](#))
- Noise Gate (switchable, [section 2.14](#))
- EQ card slot ([section 2.15](#))
- SXL II data port (RS 485)
- Sequential Remote Power On/Off
- High-End Switched Power Supply with Power Factor Correction
- 2 Alive Contacts
- Digital wear-free Volume Controls
- Protection Circuits: DC, LF, HF, Thermal, Short Circuit, Current Limiter
- PHOENIX inputs and outputs
- LED indicators for SIGNAL, CLIP, PROTECT, POWER
- Temperature controlled, variable speed low noise fans
- Softstart
- Ideal for fixed installations: Controls from the back panel only
- High Tech SMT Design

3.4.3 Front & Rear View

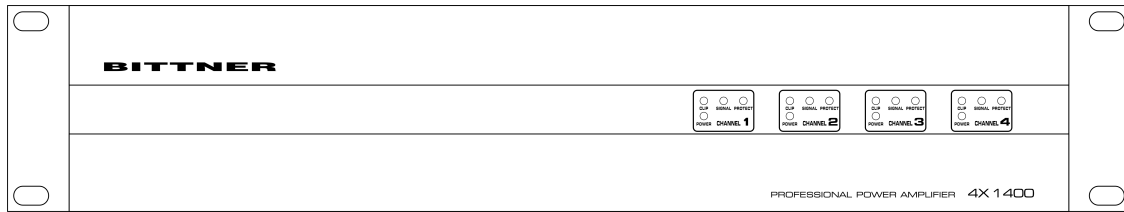

Figure 3.10: 4X Series - Front View

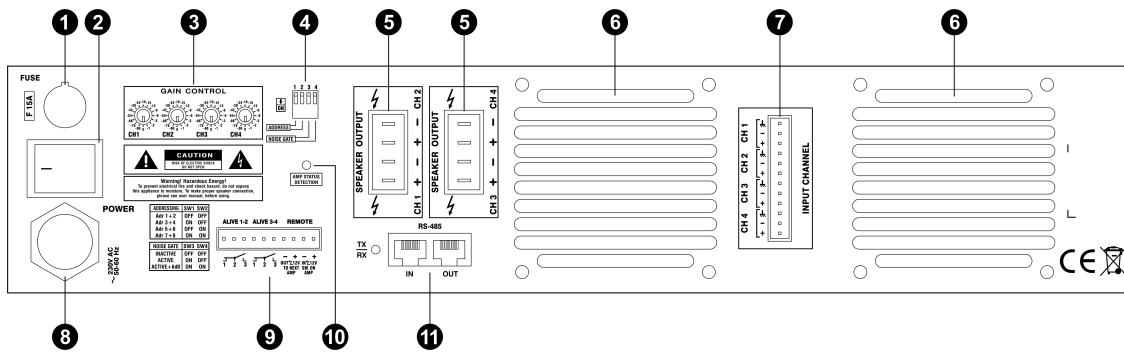
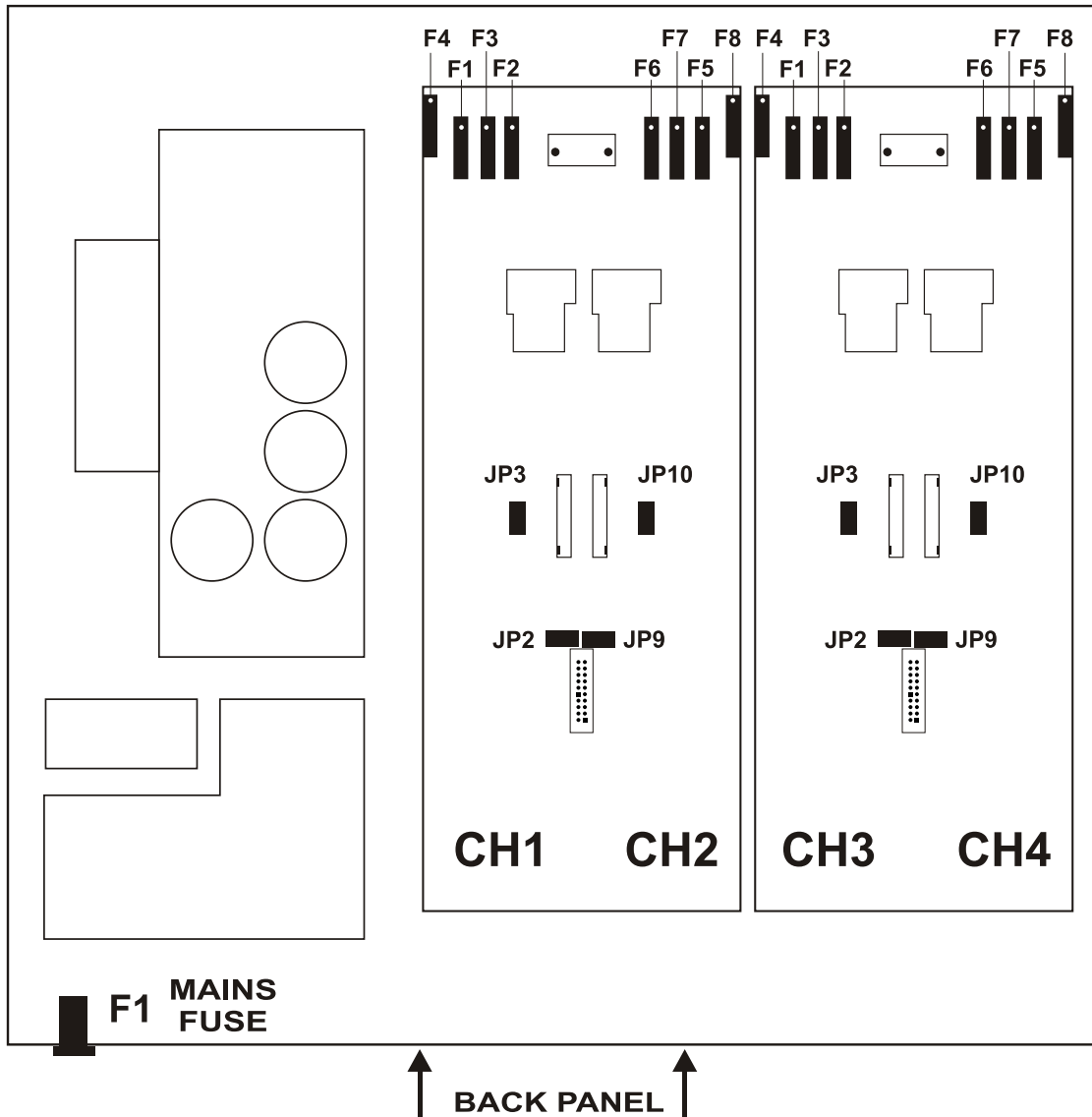

Figure 3.11: 4X Series - Rear View

Connectors and Controls of the rear panel	Reference
1 Fuse Mains Supply	
2 Mains Power Switch	section 2.1
3 Volume Controls	section 2.5.3
4 Address-ID	section 2.13
4 Noise Gate	section 2.14
5 Loudspeaker Outputs	section 2.8.1
6 Fan	
7 Audio Inputs	section 2.6.1
8 powerCON Connector	
9 Alive Contacts	section 2.10
9 Remote Power On/Off	section 2.3.1
10 Status LED	section 2.4.2
11 RS-485 Data Port	section 2.12

3.4.4 Jumper and Fuses



CHANNEL 1		CHANNEL 2		CHANNEL 3		CHANNEL 4		
FUSE		FUSE		FUSE		FUSE		
F1	F10A L 250V	F5	F10A L 250V	F1	F10A L 250V	F5	F10A L 250V	
F2	F6,3A L 250V	F6	F6,3A L 250V	F2	F6,3A L 250V	F6	F6,3A L 250V	
F3	F6,3A L 250V	F7	F6,3A L 250V	F3	F6,3A L 250V	F7	F6,3A L 250V	
F4	F10A L 250V	F8	F10A L 250V	F4	F10A L 250V	F8	F10A L 250V	
JUMPER	OPEN	CLOSE	JUMPER	OPEN	CLOSE	JUMPER	OPEN	CLOSE
JP2	EQ installed	EQ not installed	JP9	EQ installed	EQ not installed	JP2	EQ installed	EQ not installed
JP3	EQ H.Pass ON	EQ H.Pass OFF	JP10	EQ H.Pass ON	EQ H.Pass OFF	JP3	EQ H.Pass ON	EQ H.Pass OFF
MAINS FUSE F1 F12A L 250V								

Figure 3.12: 4X Series - Jumper and Fuses

3.5 4Xi/4Xe Series

3.5.1 General Information

The new 4X – Groundbreaking technology for event and installation! Much more than just power!

Bittner 4X: 4x superior sound and solid durability, combined with amazing and leading technology. The next challenge may come!

Audio networking via Dante™ (optional). Control via Ethernet (with SXL II) – worldwide diagnostics and maintenance via the Internet. Mission Possible!

Four in one: front or rear controls, analog or digital inputs (whatever the application requires). XLR or Phoenix input connectors, Speakon or Phoenix output connectors – the concept of the 4X is as flexible as its applications.

3.5.2 Features

- Up to 4x 2000 W in only 2 RU
- For event (e version) or installation (i version)
- Impedance measurement ([section 2.16](#))
- Selectable Clip Limiter (hard/soft)
- 4-channel Dante™ inputs (optional)
- SXL II data port (RS485)
- High Tech SMT Design
- Excellent sound and superior impulse response
- 2 separate stereo amplifiers
- Ready for 2 Ohm operation
- Protection Circuits: DC, LF, HF, Thermal, Short Circuit, Current Limiter, 3 ms Muting Delay
- XLR inputs and Speakon outputs (e version)
- Phoenix in- and outputs (i version)
- High-End switched power supply with PFC
- LED indicators for SIGNAL, CLIP, PROTECT, POWER
- Temperature controlled, variable speed low noise fans
- Digital wear-free Volume Controls (can be operated manually)
- Selectable Stereo/Bridged Mode
- Softstart
- Sequential Remote Power On
- 2 Alive Contacts

3.5.3 Front & Rear View 4Xi

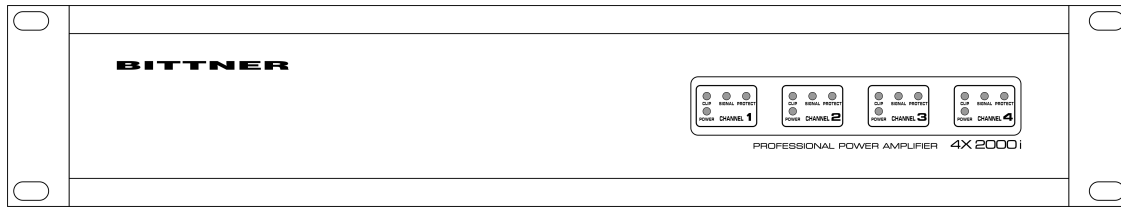

Figure 3.13: 4Xi Series - Front View

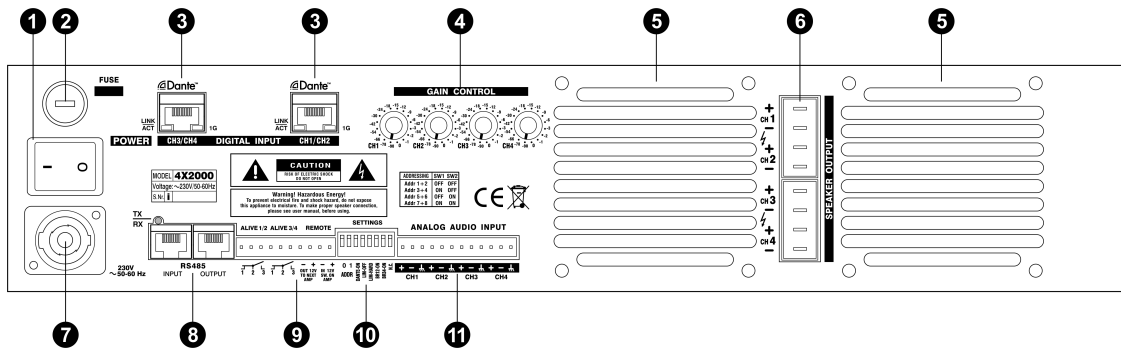

Figure 3.14: 4Xi Series - Rear View

Connectors and Controls of the rear panel	Reference
1 Mains Power Switch	section 2.1
2 Fuse Mains Supply	
3 Audio Inputs Dante™ (optional)	section 3.5.8
4 Volume Controls	section 2.5.2
5 Fan	
6 Loudspeaker Outputs	section 2.8.1
7 powerCON Connector	
8 RS-485 Data Port	section 2.12
9 Alive Contacts	section 2.10
9 Remote Power On/Off	section 2.3.1
10 DIP Switches	
Address-ID	section 2.13
DANTE™ On/Off	section 3.5.8
Clip Limiter	section 3.5.7
Operation Mode	section 2.9
11 Audio Inputs PHOENIX	section 2.6.1

3.5.4 Front & Rear View 4Xe

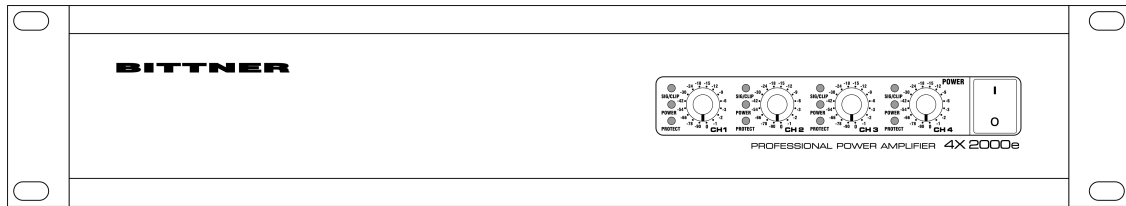

Figure 3.15: 4Xe Series - Front View

Connectors and Controls of the front panel	Reference
Mains Power Switch	section 2.1
Volume Controls	section 2.5.2

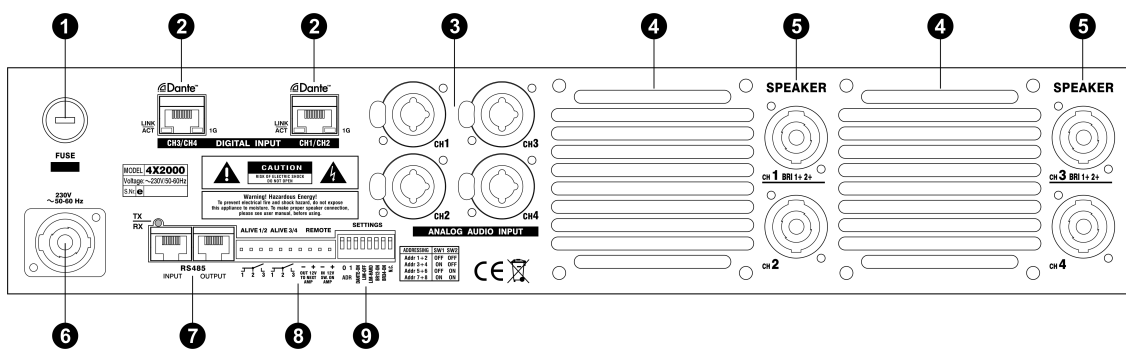
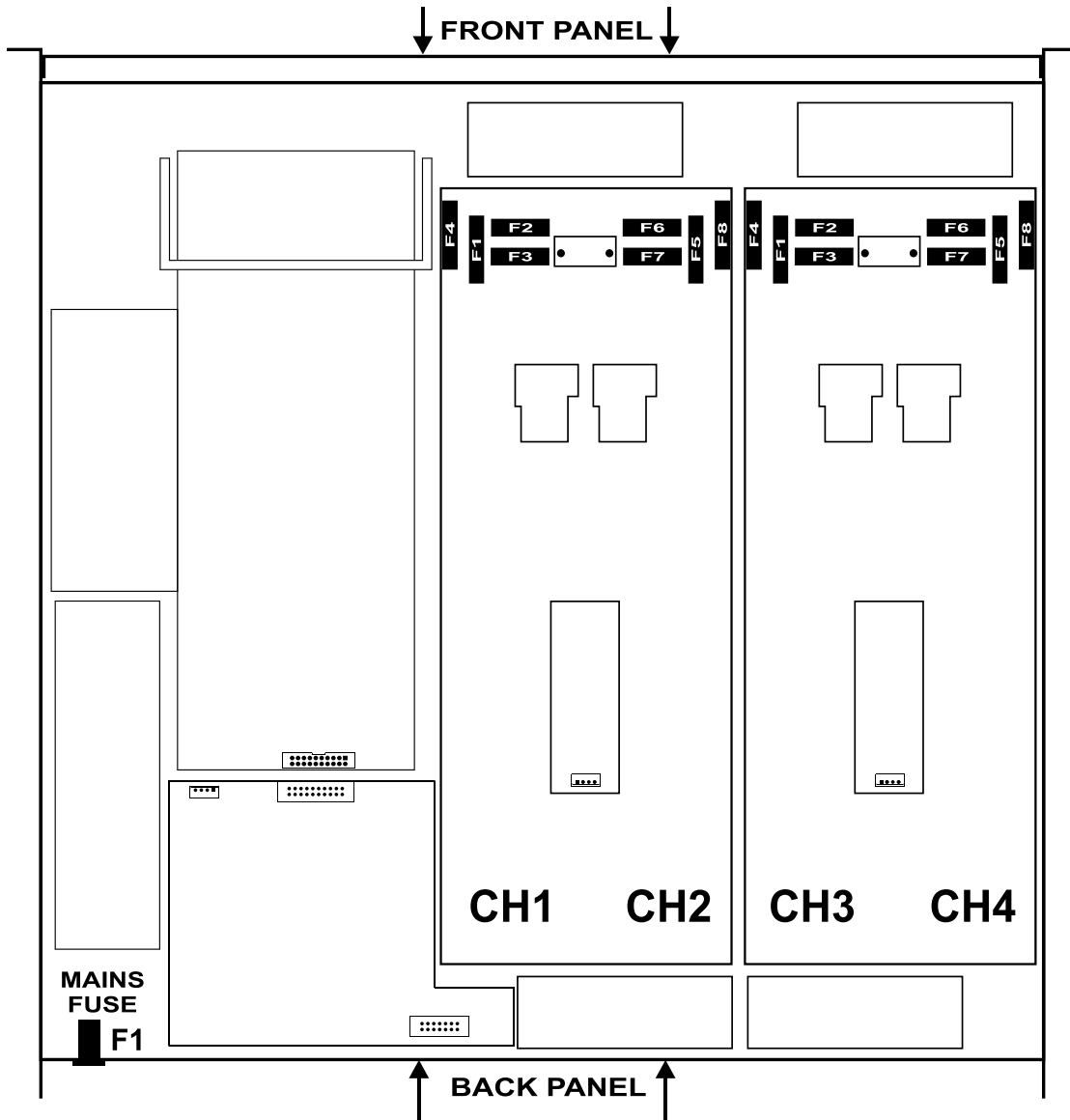

Figure 3.16: 4Xe Series - Rear View

Connectors and Controls of the rear panel	Reference
1 Fuse Mains Supply	
2 Audio Inputs Dante™ (optional)	section 3.5.8
3 Audio Inputs COMBO	section 2.6.2
4 Fan	
5 Loudspeaker Outputs SPEAKON	section 3.5.6
6 powerCON Connector	
7 RS-485 Data Port	section 2.12
8 Alive Contacts	section 2.10
8 Remote Power On/Off	section 2.3.1
9 DIP Switches	
Address-ID	section 2.13
DANTE™ On/Off	section 3.5.8
Clip Limiter	section 3.5.7
Operation Mode	section 2.9

3.5.5 Fuses



4X1200e, 4X1200i			
FUSE	CHANNEL 1+3	FUSE	CHANNEL 2+4
F1	F10A L 250V	F5	F10A L 250V
F2	F6,3A L 250V	F6	F6,3A L 250V
F3	F6,3A L 250V	F7	F6,3A L 250V
F4	F10A L 250V	F8	F10A L 250V
MAINS FUSE F1 F12,5A L 250V			

4X2000e, 4X2000i			
FUSE	CHANNEL 1+3	FUSE	CHANNEL 2+4
F1	F16A L 250V	F5	F16A L 250V
F2	F8A L 250V	F6	F8A L 250V
F3	F8A L 250V	F7	F8A L 250V
F4	F16A L 250V	F8	F16A L 250V
MAINS FUSE F1 F15A L 250V			

Figure 3.17: 4Xi/4Xe Series - Fuses

3.5.6 Loudspeaker Output Connectors 4Xe

The pin-out of the SPEAKON connectors are as follows:

SPEAKON Channel 1

Pin	Signal
1+	Channel 1+
1-	Channel 1-
2+	Channel 2+
2-	Channel 2-

SPEAKON Channel 2

Pin	Signal
1+	Channel 2+
1-	Channel 2-

SPEAKON Channel 3

Pin	Signal
1+	Channel 3+
1-	Channel 3-
2+	Channel 4+
2-	Channel 4-

SPEAKON Channel 4

Pin	Signal
1+	Channel 4+
1-	Channel 4-

The dual assignment of the SPEAKON-jack pins in channel 1 and 3 allow for the use of a single SPEAKON plug for bridged operation (cables with 2-conductors) or Bi-Amping (cables with 4-conductors).

3.5.7 Clip Limiter

The 4Xi and 4Xe series feature a switchable Clip Limiter (DIP-switch [section 3.5.9](#)).

The clip limiter reduces signal peaks to avoid unwanted signal distortion. It activates 0.5 dB below a distortion of 1% THD.

An additional DIP switch (refer to [section 3.5.9](#)) sets the clip limiter to an either *Hard* (faster) or *Soft* (slower) response.

3.5.8 Dante™ Inputs

The amplifier may be optionally equipped with a Dante™ (audio) interface. The interface complements the amplifier with 4 additional inputs.

Older Dante™ cards use two RJ-45 input with 2 audio channels each. Newer cards provide one RJ-45 input for all 4 audio channels.



Figure 3.18: 4Xi/4Xe Series - Dante™ Ports

The digital inputs may be engaged by means of a DIP switch (refer to [section 3.5.9](#)).



Caution

The analog inputs remain active regardless of the use of the Dante™ interface.

3.5.9 DIP Switches

The amplifier backside features a block of 8 DIP switches:

Switch	Function
1 + 2	Address-IDs (refer to section 2.13)
3	Dante™ Inputs On/Off
4	Clip Limiter On/Off
5	Characteristic Clip Limiter: Soft = OFF /Hard = ON
6	Bridged Operation for channel 1 and 2 (refer to section 2.9.4)
7	Bridged Operation for channel 3 and 4 (refer to section 2.9.4)
8	not in use

3.6 4X DUAL Series

3.6.1 General Information

Two for One.

Straight forward. No compromises. The 4X DUAL combines two separate 2-channel amplifiers in one chassis.

Peak performance in a double pack.

3.6.2 Features

- 2 separate stereo amplifiers
- 2 separate power supplies
- 2 High-End toroidal transformers
- Digital wear-free Volume Controls
- Sequential Remote Power On/Off
- SXL II data port (I²C)
- Noise Gate (switchable, [section 2.14](#))
- Protection Circuits: DC, LF, HF, Thermal, Short Circuit, Current Limiter
- PHOENIX inputs and outputs
- LED indicators for SIGNAL, CLIP, PROTECT, POWER
- Temperature controlled, variable speed low noise fans
- Softstart
- Ideal for fixed installations: Controls from the back panel only
- High Tech SMT Design

3.6.3 Front & Rear View

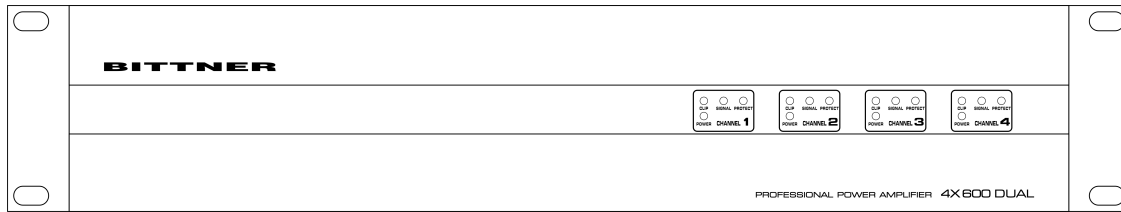

Figure 3.19: 4X DUAL Series - Front View

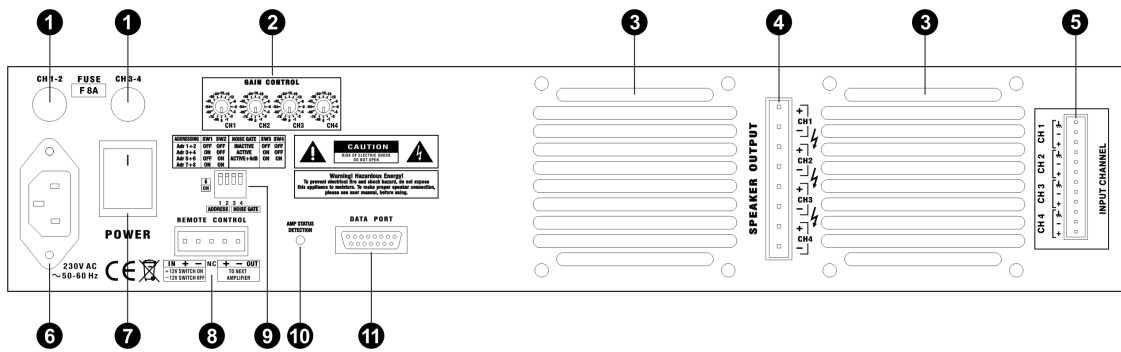
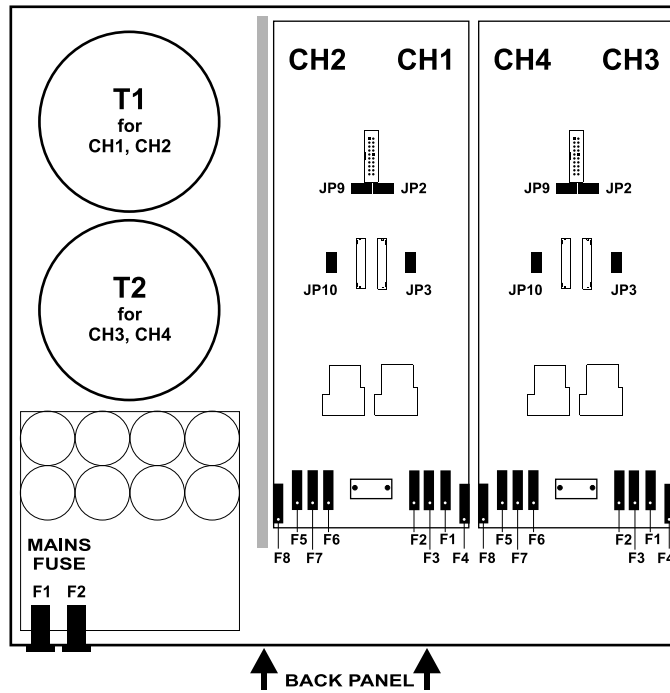

Figure 3.20: 4X DUAL Series - Rear View

Connectors and Controls of the rear panel	Reference
1 Fuse mains Supply	
2 Volume Controls	section 2.5.3
3 Fan	
4 Loudspeaker Outputs	section 2.8.1
5 Audio Inputs	section 2.6.1
6 Pluggable Mains Cord	
7 Mains Power Switch	section 2.1
8 Remote Power On/Off	section 2.3.1
9 Address-ID	section 2.13
9 Noise Gate	section 2.14
10 Status LED	section 2.4.2
11 I ² C Data Port	section 2.12.1

3.6.4 Jumper and Fuses



CHANNEL 1			CHANNEL 2			CHANNEL 3			CHANNEL 4		
FUSE			FUSE			FUSE			FUSE		
F1	F10A L 250V		F5	F10A L 250V		F1	F10A L 250V		F5	F10A L 250V	
F2	F5A L 250V		F6	F5A L 250V		F2	F5A L 250V		F6	F5A L 250V	
F3	F5A L 250V		F7	F5A L 250V		F3	F5A L 250V		F7	F5A L 250V	
F4	F10A L 250V		F8	F10A L 250V		F4	F10A L 250V		F8	F10A L 250V	
JUMPER	OPEN	CLOSE	JUMPER	OPEN	CLOSE	JUMPER	OPEN	CLOSE	JUMPER	OPEN	CLOSE
JP2	EQ installed	EQ not installed	JP9	EQ installed	EQ not installed	JP2	EQ installed	EQ not installed	JP9	EQ installed	EQ not installed
JP3	EQ H,Pass ON	EQ H,Pass OFF	JP10	EQ H,Pass ON	EQ H,Pass OFF	JP3	EQ H,Pass ON	EQ H,Pass OFF	JP10	EQ H,Pass ON	EQ H,Pass OFF
MAINS FUSE F1 F8A L 250V						MAINS FUSE F2 F8A L 250V					

Figure 3.21: 4X DUAL Series - Jumper and Fuses

3.7 8X Series



Caution

Production of the model 8X100 stopped in October 2023.

3.7.1 General Information

Setting Standards.

Multiple reliability. Meeting the highest demands in sound and flexibility.

With two separate power supplies, an integrated noise gate per channel, sequential remote power On/Off, alive contacts for every channel pair, and computer control.

To master a complete installation with only one power pack – that's what we call a standard.

3.7.2 Features

- Up to 8x 400 W @ 4 Ohm in only 2 RU
- 4 separate amplifiers
- 2 High-End toroidal transformers
- 2 separate power supplies
- 4 Alive Contacts
- Sequential Remote Power On
- Digital wear-free Volume Controls
- SXL II Data Port (I²C)
- Noise Gate (switchable, [section 2.14](#))
- EQ card slot ([section 2.15](#))
- Protection Circuits: DC, LF, HF, Thermal, Short Circuit, Current Limiter
- PHOENIX inputs and outputs
- LED indicators for SIGNAL, CLIP, PROTECT, POWER
- Temperature controlled, variable speed low noise fans
- Softstart
- Ideal for fixed installations: Controls from the back panel only
- High Tech SMT Design

3.7.3 Front & Rear View

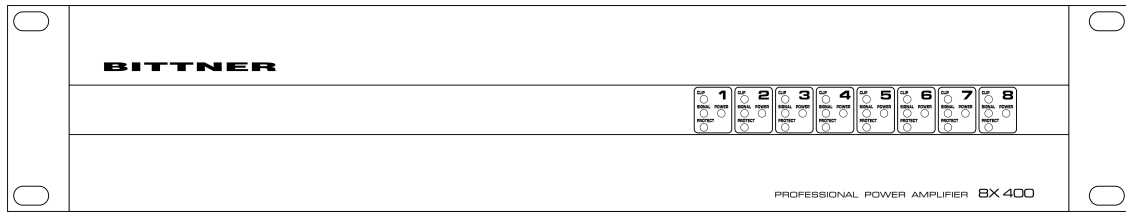

Figure 3.22: 8X Series - Front View

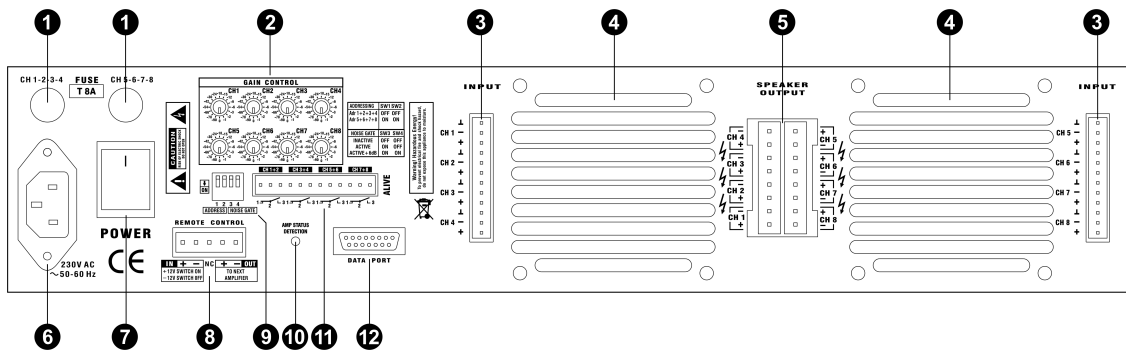
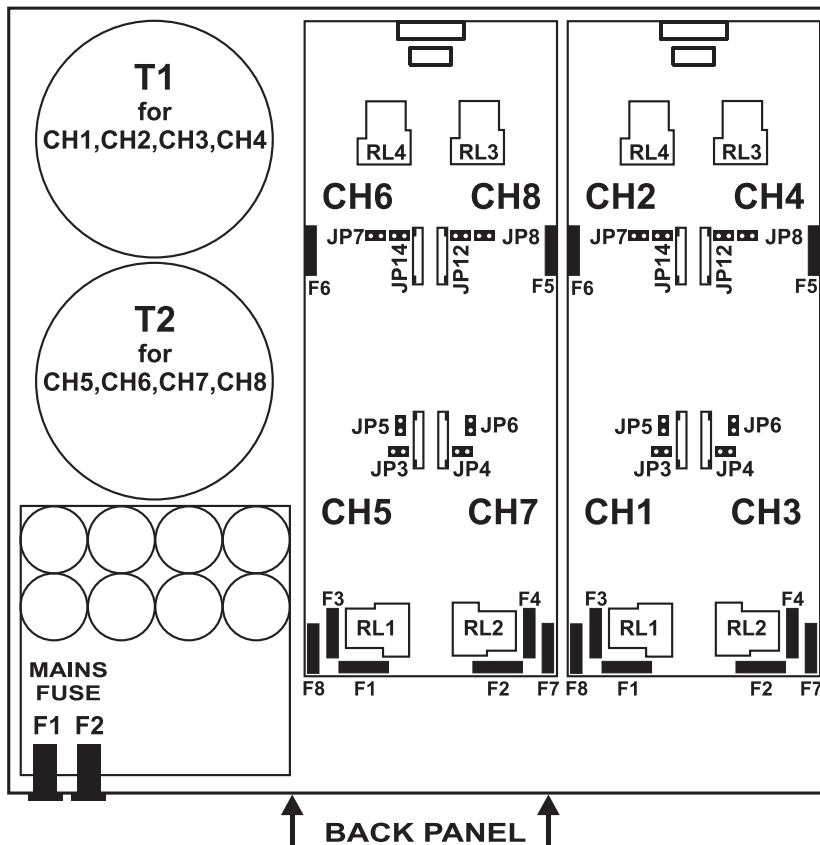

Figure 3.23: 8X Series - Rear View

Connectors and Controls of the rear panel	Reference
1 Fuse Mains Supply	
2 Volume Control	section 2.5.3
3 Audio Inputs	section 2.6.1
4 Fan	
5 Loudspeaker Outputs	section 2.8.1
6 Pluggable Mains Cord	
7 Mains Power Switch	section 2.1
8 Remote Power On/Off	section 2.3.1
9 Address-ID	section 2.13
10 Noise Gate	section 2.14
11 Status LED	section 2.4.2
12 Alive Contacts	section 2.10
12 I²C Data Port	section 2.12.1

3.7.4 Jumper and Fuses



CHANNEL 1,5			CHANNEL 2,6		
FUSE	F1	F5A L 250V	FUSE	F6	F5A L 250V
	F3	F5A L 250V		F8	F5A L 250V
JUMPER	OPEN	CLOSE	JUMPER	OPEN	CLOSE
JP5	EQ installed	EQ not install.	JP7	EQ installed	EQ not install.
JP3	EQ H.Pass ON	EQ H.Pass OFF	JP14	EQ H.Pass ON	EQ H.Pass OFF
CHANNEL 3,7			CHANNEL 4,8		
FUSE	F2	F5A L 250V	FUSE	F5	F5A L 250V
	F4	F5A L 250V		F7	F5A L 250V
JUMPER	OPEN	CLOSE	JUMPER	OPEN	CLOSE
JP6	EQ installed	EQ not install.	JP8	EQ installed	EQ not install.
JP4	EQ H.Pass ON	EQ H.Pass OFF	JP12	EQ H.Pass ON	EQ H.Pass OFF
MAINS FUSE F1 F8A L 250V for CH1-2-3-4			MAINS FUSE F2 F8A L 250V for CH5-6-7-8		

Figure 3.24: 8X Series - Jumper and Fuses

3.8 XV Series

3.8.1 General Information

Power for Professionals.

Made for PA/VA applications, BGM, music and acoustic alarm signals. Stable, constantly monitored, versatile, and dynamic.

Needless to say that the XV high-end toroidal output transformers are some of the very best. The XV effortlessly deals with all situations and jobs.

3.8.2 Features

- Perfect for fixed installations
- High Tech SMT Design
- Excellent sound and superior impulse response
- Protection Circuits: DC, LF, HF, Thermal, Short Circuit, Current Limiter
- PHOENIX input and output connectors
- High-End Toroidal Output 100V Transformers
- Temperature controlled, variable speed low noise fans
- Analog Volume Controls on the rear panel
- EQ Card Slot ([section 2.15](#))
- LED Indicators for POWER, SIGNAL, CLIP, PROTECT and OVERHEAT ([section 2.4.1](#))
- Stereo/Parallel Mode
- Softstart
- Sequential remote power On/Off
- Alive Contact
- Ground Lift

3.8.3 Front & Rear View

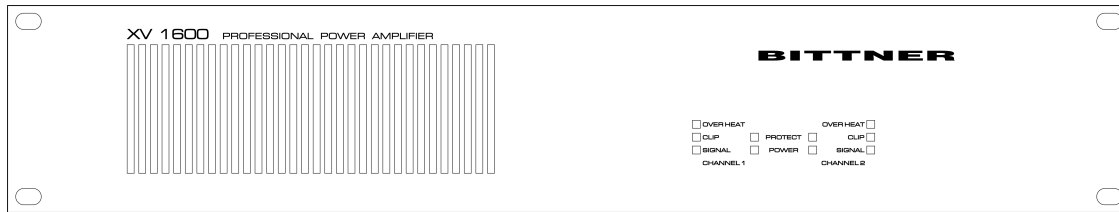

Figure 3.25: XV Series - Front View

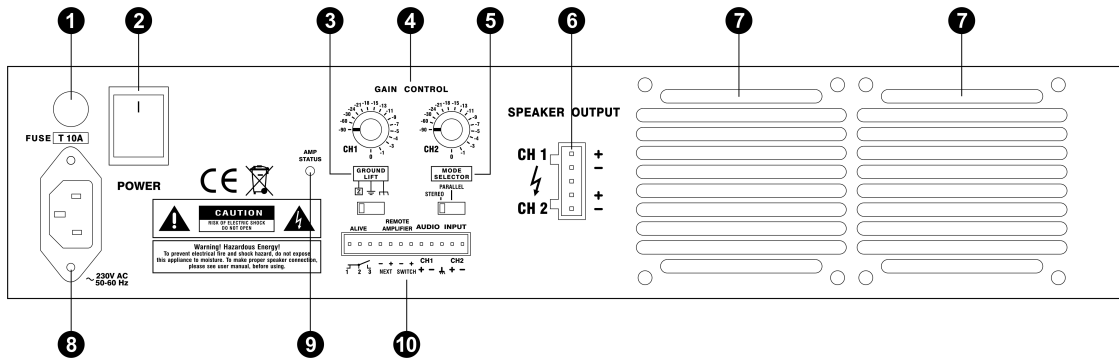

Figure 3.26: XV Series - Rear View

Connectors and Controls of the rear panel	Reference
1 Fuse Mains Supply	
2 Mains Power Switch	section 2.1
3 Ground Lift	section 2.7
4 Volume Controls	section 2.5.1
5 Operation Mode	section 2.9
6 Loudspeaker Outputs	section 2.8.1
7 Fan	
8 Pluggable Mains Cord	
9 Status LED	section 2.4.2
10 Alive Contact	section 2.10
10 Remote Power On/Off	section 2.3.1
10 Audio Inputs	section 2.6.1

3.8.4 Jumper and Fuses

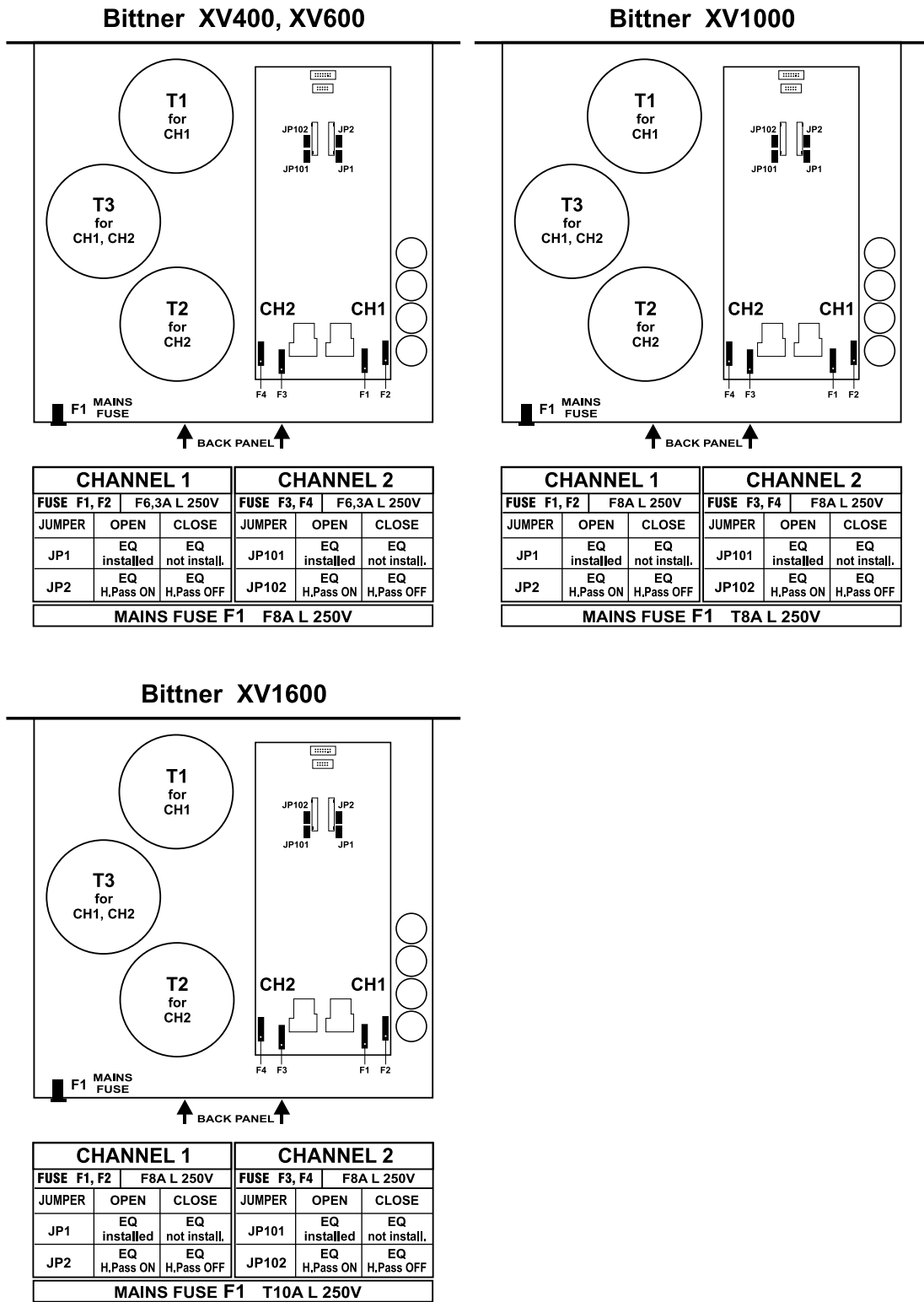

Figure 3.27: XV Series - Jumper and Fuses

3.9 XV DC Series

3.9.1 General Information

When it Comes to the Ultimate.

Sovereign dependability and seamless switching over to 24 VDC in case of a loss of mains power. Without diminishing its performance or a reduction of output power.

In accordance with the most stringent safety regulations (EN 54–16).

Designed for voice evacuation, public announcements and background music (BGM) with uncompromised audio performance.

Reliability has a new face.

3.9.2 Features

- 24 volts backup power
- High power, high efficiency SMPS with PFC
- Sequential remote power On/Off
- Alive contact
- DC power-fail signalization
- High-End Toroidal Output 100V Transformers
- LED Indicators for POWER, SIGNAL, CLIP, PROTECT, AC POWER, DC POWER ([section 2.4.1](#))
- Protection Circuits: DC, LF, HF, Thermal, Short Circuit, Current Limiter
- Temperature controlled, variable speed low noise fans
- Analog volume controls
- Softstart
- High Tech SMT Design

3.9.3 Front & Rear View

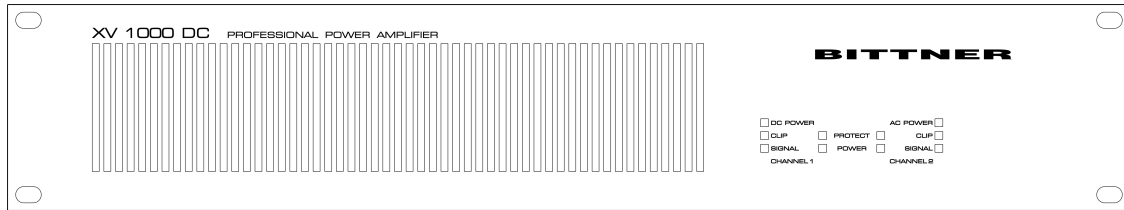

Figure 3.28: XV DC Series - Front View

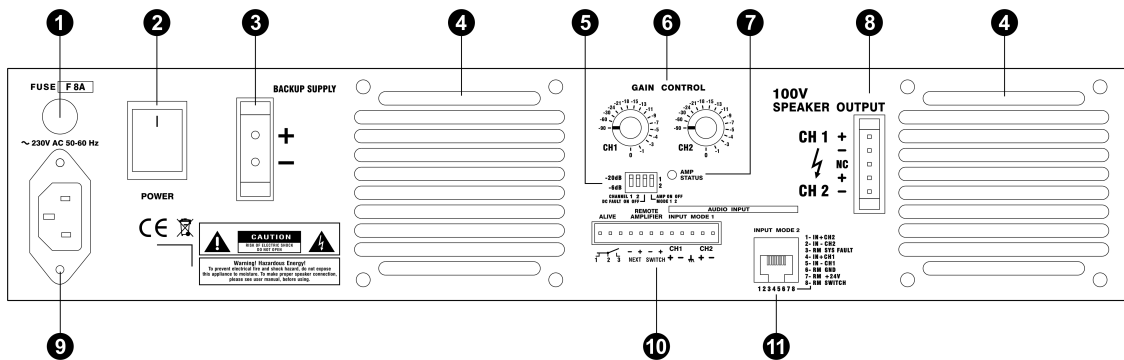

Figure 3.29: XV DC Series - Rear View

Connectors and Controls of the rear panel	Reference
1 Fuse Mains Supply	
2 Mains Power Switch	section 2.1
3 Backup Power Connector	section 2.2
4 Fan	
5 DIP Switch	section 3.9.4
6 Volume Controls	section 2.5.1
7 Status LED	section 2.4.2
8 100V Loudspeaker Outputs	section 2.8.1
9 Pluggable Mains Cord	
10 Alive Contact	section 2.10
10 Remote Power On/Off	section 2.3.1
10 Audio Inputs	section 2.6.1
11 Multifunction Connector	section 2.11

3.9.4 DIP Switches

The amplifier backside features a block of 4 DIP switches:

Switch	Function
1	Sets the sensitivity of the Signal LED of channel 1. The LED indicates either a signal level of more than -20dB or -6dB
2	Sets the sensitivity of the Signal LED of channel 2. The LED indicates either a signal level of more than -20dB or -6dB
3	Sets the <i>RM SYS FAULT</i> output to indicate a fault of the 24V backup supply (refer to section 2.11.3).
4	Selects the remote power on voltage +/-12V (Mode 1, refer to section 2.3.1) or 24V (Mode 2, refer to section 2.11.2). Please note: In <i>Mode 2</i> the amplifier may be switched on only by a control voltage of 24V and the mains power switch is disabled.



Figure 3.30: XV DC Series - DIP Switches

3.10 2DXV Series

3.10.1 General Information

Power. Sound. Efficiency.

Take one get more. The 2DXV500 and 2DXV300 amplifiers are powerful, universal, ultra-compact tools for the most demanding applications. Designed and manufactured for the comfort of entertainment and information. And highest safety requirements.

Switchable 100/70 volts direct outputs, stereo or mono:

- 2x 300 W at 100 or 70 V or 8 ohms (2DXV300)
- 2x 500 W at 100 or 70 V or 8 ohms (2DXV500)
- 1x 600 W at 100 or 70 V or 8 ohms (2DXV300)
- 1x 1000 W at 100 or 70 V or 8 ohms (2DXV500)

Combined with a backup power supply of 24 V DC.

3.10.2 Features

- Class D
- 100/70 volts direct output (switchable)
- 24 volts backup power
- Full continuous output power even during battery operation
- High power, high efficiency SMPS
- Efficiency > 80%
- Sleep Mode (refer to [section 3.10.4](#))
- 70 Hz High Pass Filter (switchable, refer to [section 3.10.5](#))
- Analog volume controls (at the back)
- Sequential remote power On/Off
- Alive contact
- DC and AC power-fail signalization
- LED Indicators for POWER, SIGNAL, CLIP, PROTECT, AC POWER, DC POWER, SLEEP, MONO MODE (refer to [section 2.4.1](#))
- Protection circuits: DC, LF, HF, Thermal, Short Circuit, Current Limiter
- Temperature controlled, variable speed, low noise fans
- Softstart
- High Tech SMT Design
- Depth of chassis only 30 cm

3.10.3 Front & Rear View

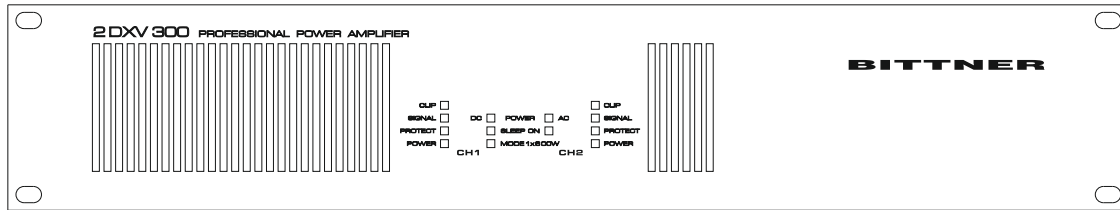

Figure 3.31: 2DXV Series - Front View

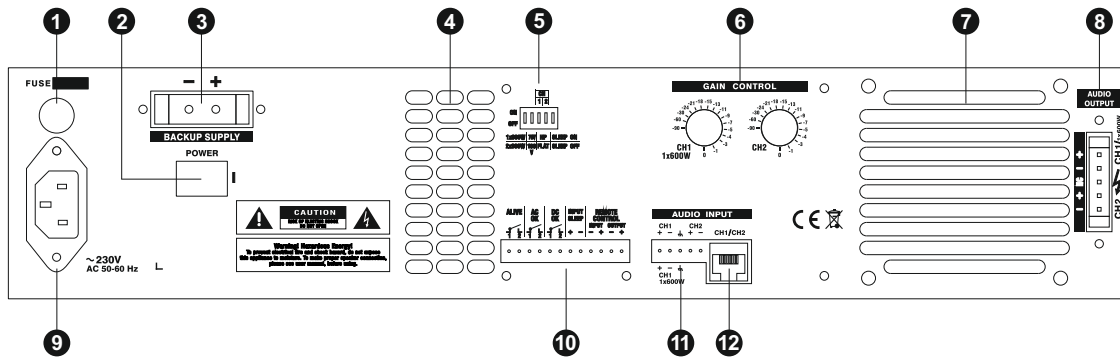

Figure 3.32: 2DXV Series - Back View

Connectors and Controls of the rear panel	Reference
1 Fuse Mains Supply	
2 Mains Power Switch	section 2.1
3 Backup Power Connector	section 2.2
4 Fan	
5 DIP Switch	section 3.10.6
6 Volume Controls	section 2.5.1
7 Fan	
8 100/70V Loudspeaker Outputs	section 2.8.1
9 Pluggable Mains Cord	
10 Alive Contact	section 2.10
10 Control Input Sleep Mode	section 3.10.4
10 Remote Power On/Off	section 2.3.1
11 Audio Inputs	section 2.6.1
12 Multifunction Connector	section 2.11

3.10.4 Sleep Mode

To save energy it is possible to put the amplifier channels into a sleep mode. This reduces the power consumption (refer to [section 5](#)).

The Sleep Mode can be activated in two ways:

Option 1: A voltage of +12 VDC applied to *INPUT SLEEP* puts both channels into sleep mode.

Option 2: If the DIP switch *SLEEP ON/OFF* (refer to [section 3.10.6](#)) is set to *ON* the sleep mode of each channel is controlled by the incoming audio signal individually. An audio level above the threshold of -60 dB wakes a channel within 150 ms. If the level is below the threshold for more than 5 minutes a channel is set into sleep mode.



Caution

Option 1 always overrides option 2.

3.10.5 High Pass Filter

The amplifier is equipped with individual high pass filters per channel. The filters are activated by the DIP switch on the rear panel of the amplifier.

Parameter	Value
Type	Butterworth
Frequency	70 Hz (-3 dB)
Slope	-12 dB/Octave

3.10.6 DIP Switches

The amplifier backside features a block of 5 DIP switches (from left to right):

Switch	Position	Function
1	ON	Sets the amplifier to operate in mono mode. In this mode only channel 1 is active.
	OFF	Sets the amplifier to operate in two channel mode.
2	ON	Sets the output voltage to 70 V
	OFF	Sets the output voltage to 100 V
3	ON	Activates the High Pass Filter for channel 1 (refer to section 3.10.5)
	OFF	Deactivates the High Pass Filter for channel 1 (refer to section 3.10.5)
4	ON	Activates the High Pass Filter for channel 2 (refer to section 3.10.5)
	OFF	Deactivates the High Pass Filter for channel 2 (refer to section 3.10.5)
5	ON	Activates the Sleep Mode (refer to section 3.10.4)
	OFF	Deactivates the Sleep Mode (refer to section 3.10.4)

3.11 4DXV Series

3.11.1 General Information

A Class Of Its Own.

Surpassing your expectations.

Its revolutionary Class D concept provides a superior combination of efficiency and endurance. Without any loss, even during continuous operation.

The 100 V floating direct outputs lower a lot more than just the weight: Installation and rack prices will drop significantly. And to round this off, the cost for energy consumption will average at roughly one third of any ordinary amplifier.

In addition: In case of a loss of mains power, the amplifier will automatically switch to 24 V battery power - without any loss of output power!

Sequential power up and "Alive" relays included. No doubts - a real Bittner!

3.11.2 Features

- Class D
- Discrete build of power amp modules
- 2 separate 2-channel amplifiers
- 100 volts direct output
- 24 volts backup power
- High power, high efficiency SMPS with PFC
- LED Indicators for AC POWER, DC POWER, SIGNAL, CLIP, PROTECT ([section 2.4.1](#))
- Protection circuits: DC, LF, HF, Thermal, Short Circuit, Current Limiter
- Sequential remote power on/off
- 2 alive contacts
- Temperature controlled, variable speed, low noise fans
- Volume control at the back
- High Tech SMT Design

3.11.3 Front & Rear View

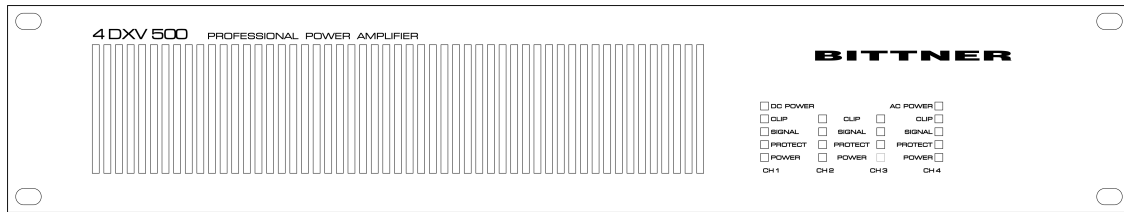

Figure 3.33: 4DXV Series - Front View

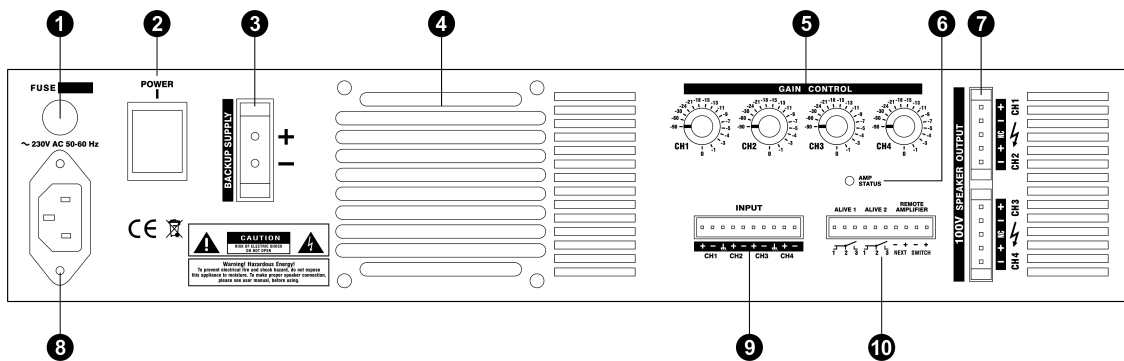

Figure 3.34: 4DXV Series - Rear View

Connectors and Controls of the rear panel	Reference
1 Fuse Mains Supply	
2 Mains Power Switch	section 2.1
3 Backup Power Connector	section 2.2
4 Fan	
5 Volume Controls	section 2.5.1
6 Status LED	section 2.4.2
7 100V Loudspeaker Outputs	section 2.8.1
8 Pluggable Mains Cord	
9 Audio Inputs	section 2.6.1
10 Alive Contacts	section 2.10
10 Remote Power On/Off	section 2.3.1

3.12 XT Series

3.12.1 General Information

Simply the Best.

Perfect frequency response and sound. Individually tested.

100 V transformers are an essential part of fixed installations. The possibility to connect many loudspeakers in parallel to a single amplifier and to have them galvanically separated is of undisputed significance. To save costs, however, low quality transformers are being used that offer only low fidelity in the lower and higher frequency range.

- Sensible power granulation
- Ultra linear frequency response
- Flux free quality
- Small size

The XT transformers are being used in the Bittner Audio XV and XV DC 100 Volt series. Bittner quality is available in every single component.

3.12.2 Connections



Figure 3.35: XT Transformer - Connection Wires and Sticker

The XT transformer comes with 4 connection wires, each with a unique color. A sticker states the color of the (+) pin.

100V: Two “thin” twisted pair wires

Low impedance (4 Ohm): Two “thicker” wires

3.13 8XT Series



Caution

Production of the model 8XT100 stopped in October 2023.

3.13.1 General Information

Bittner Audio's high quality transformers are not only available as single transformers, but come in an 8 channel chassis with only 2 RU.

Simply connect an 8X amplifier to an 8XT multichannel output transformer and you'll be ready to meet our European norms and standards.

3.13.2 Front & Rear View

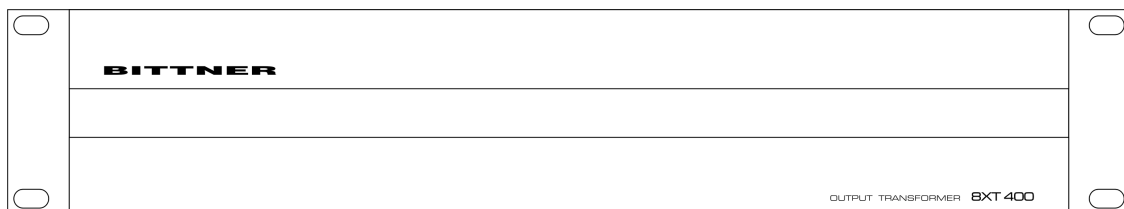

Figure 3.36: 8XT Series - Front View

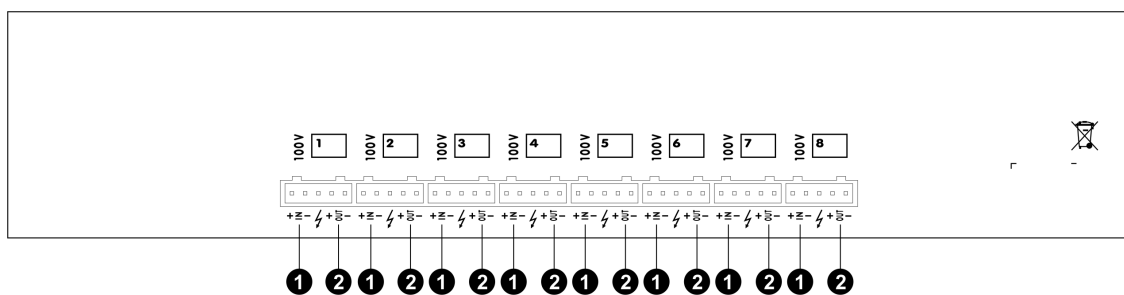

Figure 3.37: 8XT Series - Rear View

Connectors and Controls of the rear panel Reference

- 1 Amplifier Input
 - 2 Loudspeaker Output
-

3.14 AX16 - Intelligent Amplifier Switch

3.14.1 General Information

The AX16 is an Intelligent Amplifier Switch that is capable switching both, 100V and high power low-impedance amplifiers. A faulty amplifier will be completely replaced with its audio inputs and loudspeaker outputs. The switching process is microprocessor controlled and takes less than 250 ms.

The control of/by the amplifiers is established via contact closures or the SXL II Control Interface.

To maintain the volume of the system in case of a backup, the input levels are controlled through digital potentiometers and stored. As a result, the levels/volumes of all amplifier channels will remain at their set value.

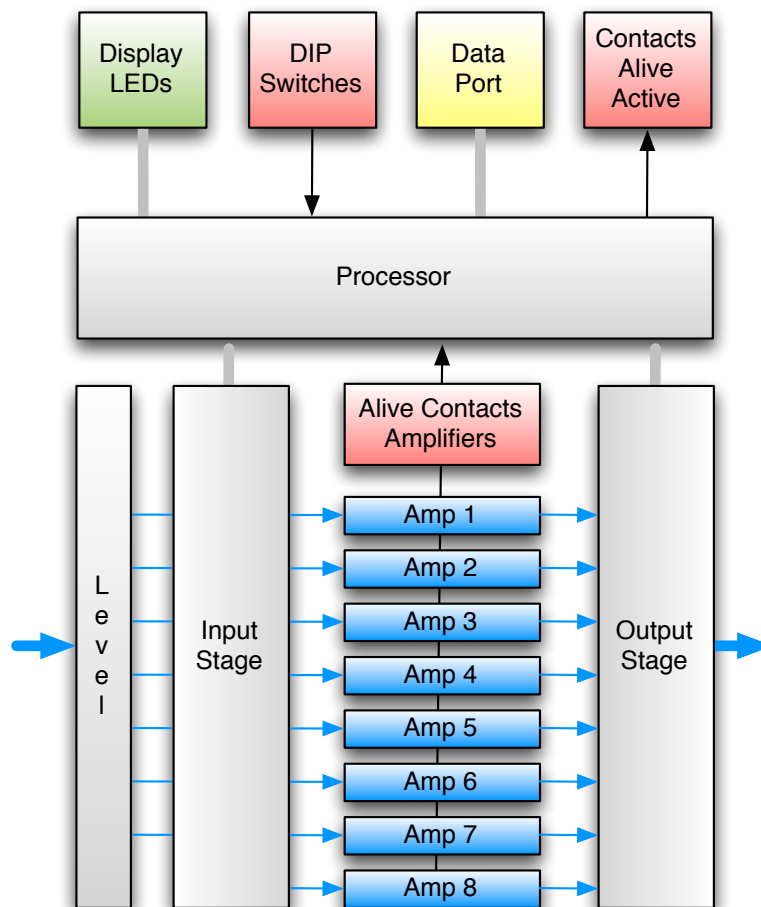

Figure 3.38: AX16 - Block Diagram

If the AX16 is connected to a Bittner Audio SXL unit, the so-called Intelligent Switching Algorithm will be activated. This algorithm transmits not only channel levels but also all parameters of an integrated DSP to the backup amplifier.

The integrated switch-over and fault detection contacts allow for easy communication with any control and monitoring system.

If connected to a Bittner Audio SXL II via data port, the AX16 will become an essential part of the Bittner Audio network for intelligent remote control and monitoring.

3.14.2 Features

- Microprocessor controlled Amplifier Switch for 16 Channels
- Switching is issued via Alive Contacts or SXL II
- Operation Modes:
 - 1 group with 2 Backup per 14 Signal Channels
 - 2 groups with 2 Backup per 6 Signal Channels
 - 4 groups with 2 Backup per 2 Signal Channels
- Digital wear-free Volume Controls
- 2 Alive Contacts: ALIVE and BACKUP OPERATION
- Output relays with max. 20 A/240V, 100V compatible
- Comprehensive LED Indicators under all conditions
- All connectors (PHOENIX) at the back
- SXL II Data Port (I²C)

3.14.3 Front & Rear View

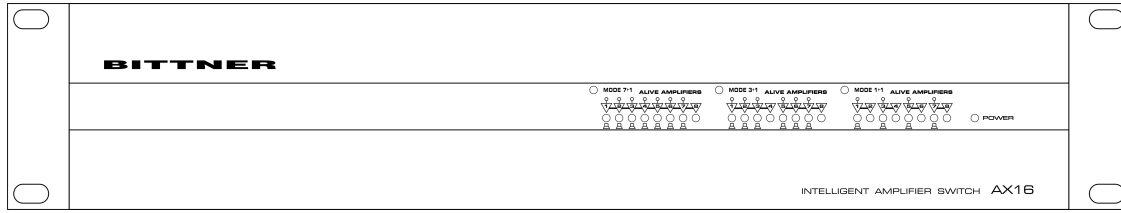

Figure 3.39: AX16 - Front View

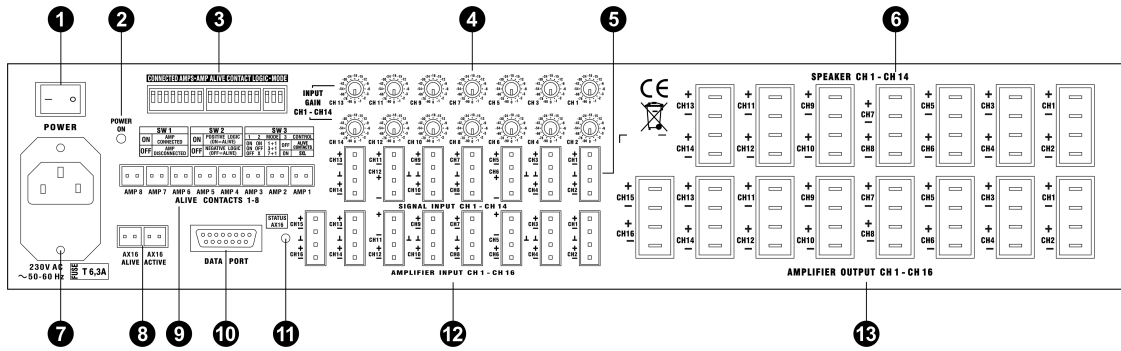

Figure 3.40: AX16 - Rear View

Anschlüsse und Bedienelemente auf der Rückseite	Referenz
1 Mains Power Switch	
2 Power On LED	section 3.14.4
3 DIP Switch	
Apmlifier connected	section 3.14.5.2
Logic Alive Contact	section 3.14.5.3
Switching Mode	section 3.14.5.1
Control Mode	section 3.14.5.4
4 Volume Controls	section 3.14.8
5 Audio Inputs	section 3.14.6.1
6 Loudspeaker Outputs	section 3.14.6.2
7 Pluggable Mains Cord	
7 Fuse Mains Supply	
8 Alive Contacts	section 3.14.9
9 Alive Inputs	section 3.14.6.3
10 I2C Data Port	section 3.14.7
11 Status LED	section 3.14.4
12 Amplifier Inputs	section 3.14.6.1
13 Amplifier Outputs	section 3.14.6.2

3.14.4 LED Indicators



Figure 3.41: AX16 - LED Indicators Frontside

LED	Color	Function
POWER	green	Indicates that the unit is powered up
Mode 7 + 1	red	Indicates the Mode 7+1
Amplifier 1–8	8x red	Indicates the active amplifiers
Mode 3+1	red	Indicates the Mode 3+1
Amplifier 1–8	8x red	Indicates the active amplifiers
Mode 1+1	red	Indicates the Mode 1+1
Amplifier 1–8	8x red	Indicates the active amplifiers

If one amplifier is switched to the backup amplifier, the LED of the amplifier and the LED of the backup amplifier will flash.

In the case that another amplifier fails and cannot be switched to a backup amplifier its LED will flash fast.



Figure 3.42: AX16 - LED Indicators Backside

The AX16 is equipped with two LEDs on the rear panel of the unit for operation with the SXL II:

LED	Color	Function
POWER	green	Indicates that the unit is powered up
STATUS AX16	red	Blinks once every second under normal conditions, blinks fast in case of AX16 fault or if the mains voltage drops under 190 VAC

3.14.5 Configuration

It is possible to connect two- or multi-channel amplifiers to an AX16. In the following sections the word amplifier stands for a 2 channels. Therefore the 4X series models count as 2, the 8X series models as 4 amplifiers.

The AX16 is configured by a series of DIP switches at the back of the unit.



Figure 3.43: AX16 - DIP Switches

3.14.5.1 Switching Modes

The switching modes determine how many amplifier channels are being backed up. The switching modes are selected with DIP switches 1 and 2 of the block SW3 on the rear panel of the device.



Caution

To activate the DIP-Switch SW3 settings the AX16 has to be re-powered.

Mode 7+1	Mode 3+1	Mode 1+1
Eight amplifiers (16 channels) may be connected. Seven amplifiers (14 channels) are being used as program amplifiers and one amplifier (2 channels) as the backup amplifier.	Two groups of four amplifiers (8 channels) each may be connected. Three amplifiers (6 channels) of each group are being used as program amplifiers and one amplifier (2 channels) as the backup amplifier.	Four groups of two amplifiers (4 channels) each may be connected. One amplifier (2 channels) is being used as program amplifier and one amplifier (2 channels) is being used as the backup amplifier.

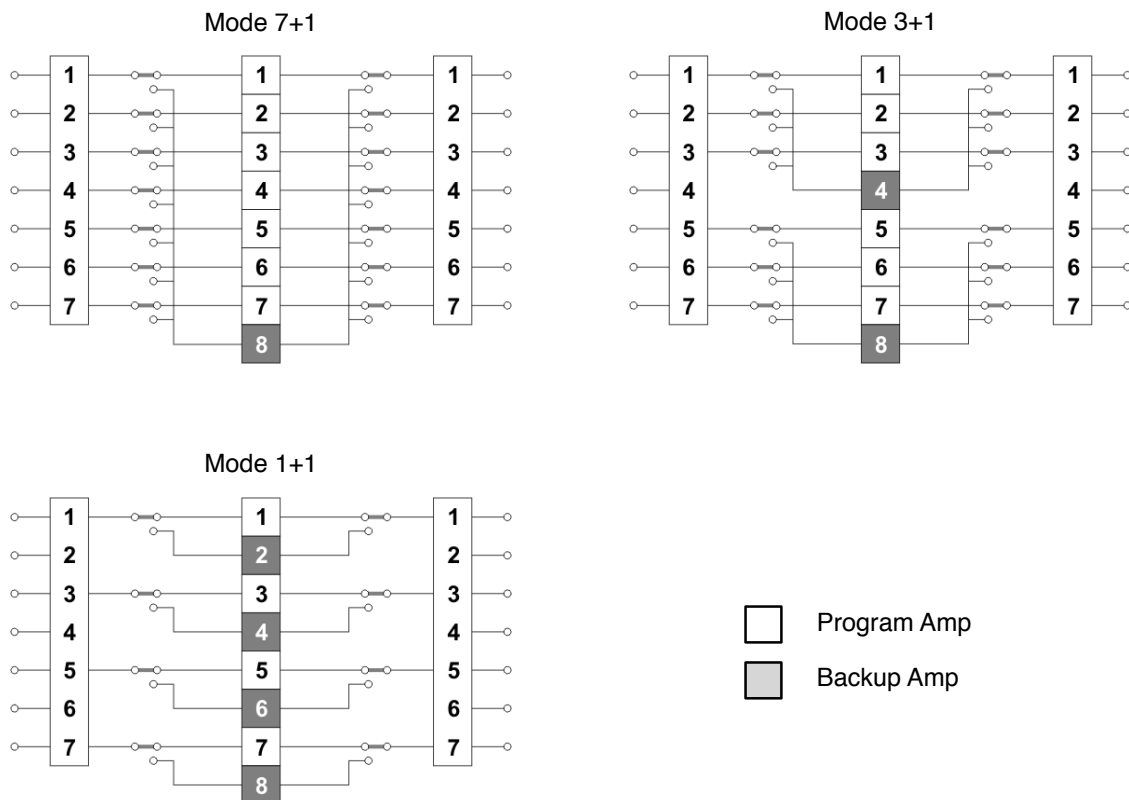

Figure 3.44: AX16 - Switching Modes

3.14.5.2 Connected Amplifiers

The DIP switches 1 to 8 of block SW1 tell the AX16 whether an amplifier is connected or not.

- ON: amplifier is connected
- OFF: no amplifier is connected or the amplifier is controlled by an SXL II (refer to Split Mode ([section 3.15.9.5](#))).

3.14.5.3 Logic of Alive Contact

The DIP switches 1 to 8 of block SW2 determine the control logic of the connected alive contacts in case of a failure:

- ON: positive logic (contact open if amp fails)
- OFF: negative logic (contact closed if amp fails)



Caution

If the AX16 is connected to an SXL II, these DIP switches are disabled for every amplifier, which is also connected via its data port to the SXL II (refer to Split Mode ([section 3.15.9.5](#))).

3.14.5.4 Control Modes

The backup switching may be activated in two different ways, which are selected by DIP switch 3 of block SW3:

- ON: Control by a connected SXL II
- OFF: Control by the ALIVE contacts of the connected amplifiers or any other potential-free contact



Caution

In case of using contact closures and the SXL II (refer to Split Mode ([section 3.15.9.5](#))), the DIP switch has to be set to ON.

When using the contact inputs, a single contact will control one amplifier (2 channels). This contact is directly compatible with the ALIVE (fault detection) contacts of Bittner Audio amplifiers.

In addition, any other potential-free contact may be used. The switching will take place after the contact has been activated (amplifier defect will be indicated by either an opened or a closed contact). This logic operation (positive-negative) needs to be set with DIP Switch block SW 2 for each amplifier.

3.14.6 Connection of Amplifiers

3.14.6.1 Signal and Amplifier Inputs

The signal inputs of the individual channels may be connected to the PHOENIX terminals *Signal Input CH1 – CH14*.

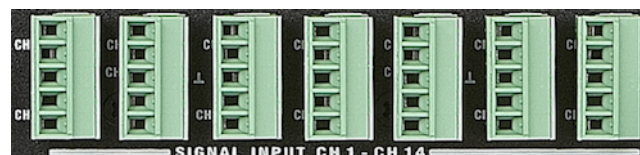

Figure 3.45: AX16 - Signal Inputs



Caution

Since the backup amplifier does not have its own input, only 14 inputs are needed on the AX16. The input signal of the backup amplifier is made up of the input channels of the faulty amplifier.

The input signals are then available on the PHOENIX terminals *Amplifier Input Ch1 – CH16*.

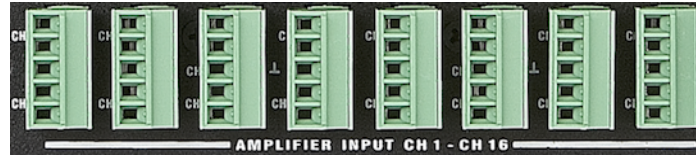

Figure 3.46: AX16 - Amplifier Inputs



Caution

In case of failure, the backup amplifier will receive its audio signal from the AX16. This is the reason why 16 channels (AX16 -> amplifiers) are available.

3.14.6.2 Amplifier Outputs and Loudspeakers

The amplifier power outputs (including the outputs of the backup amplifier) need to be connected to the PHOENIX terminals labeled *Amplifier Output CH1 – CH16* on the AX16. Depending on the selected mode, the power outputs are switched to the appropriate loudspeaker lines.



Figure 3.47: AX16 - Amplifier Outputs

The loudspeakers may be connected to the terminals *Speaker CH1 – Ch14* on the AX16.



Figure 3.48: AX16 - Loudspeaker Outputs



Caution

In line with the input configuration 14 loudspeaker and 16 amplifier connectors are available.

3.14.6.3 Alive Contact of the Amplifiers

If the AX16 is controlled by the alive contact of an amplifier, the corresponding contacts on the backside of the unit need to be connected. This includes the backup amplifier. The PHOENIX terminals offer eight contact pairs.



Figure 3.49: AX16 - Alive Contact Inputs

**Caution**

Any potential-free contact may be used for controlling.

3.14.7 Data Port

The AX16 is equipped with an I²C data port (refer to [section 2.12.1](#)) for the connection to a Bittner Audio SXL II. The connection of the AX16 to an SXL II will integrate it into the Bittner Audio monitoring system.

Bittner Audio recommends the use of the AX16 in connection with an SXL II to utilize every option of the intelligent controlling and monitoring system. If an AX16 is connected to the SXL II amplifier controlling device, the DSP parameters (if featured) will be transmitted to the backup amplifiers.

**Caution**

The level controls of the AX16, if integrated into the SXL II amplifier controlling system, need to be set to 0dB.

3.14.8 Level Control

To maintain the level/volume structure of the system, independent of the backup switching condition, it is important to control the level not on the amplifier itself but on the backup switching unit. This ensures that the level of the faulty amplifier is being applied to the backup amplifier.



Figure 3.50: AX16 - Digital Level Controls

Every potentiometer of the amplifier (including the backup amplifier) should be set to the same value (in standard operation maximum = Unity Gain).

**Caution**

If an SXL II controls the AX16, all levels will be intelligently adapted. This allows for the use of amplifiers of different power outputs in the same system. The level controls of the AX16 need to be set to 0dB.

3.14.9 Alive and Active Contacts

The condition of an AX16 is indicated by its own ALIVE contact. In addition, a status contact (ACTIVE) is available which triggers in case of the activation of the backup amplifier/mode.



Figure 3.51: AX16 - Alive Contacts

**Caution**

In case the mains supply fails, the AX16 (ALIVE contact will open) will fall back into a safety mode: all signals are directly switched to the amplifier inputs and the amplifier outputs are directly switched to the loudspeaker outputs. The digital potentiometers are bridged and the signals are switched without level control.

3.14.10 Application Examples

3.14.10.1 Mode 7+1 with Alive Contacts

In this example all 8 amplifiers are connected to the AX16 via their alive contacts. Amplifier no. 8 is the backup amplifier.

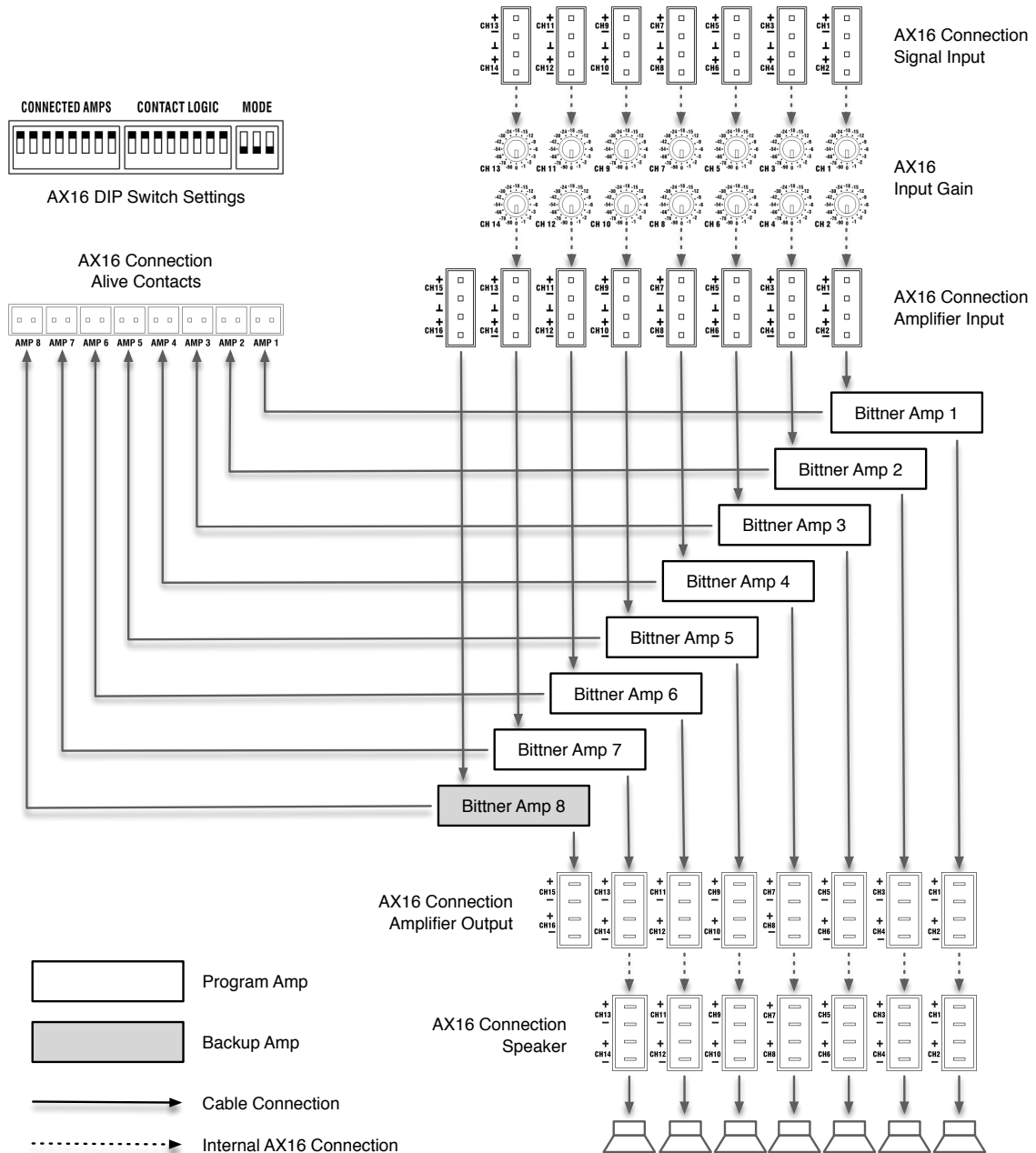

Figure 3.52: AX16 - Mode 7+1 with Alive Contacts

3.14.10.2 Mode 3+1 with SXL II and Alive Contacts

This examples contains 2 groups of 4 amplifiers each. The first group is connected to the AX16 via their alive contacts and may be 100V types. The second group is controlled through the SXL II data bus. The backup amplifiers are no. 4 for group 1 and no. 8 for group 2.

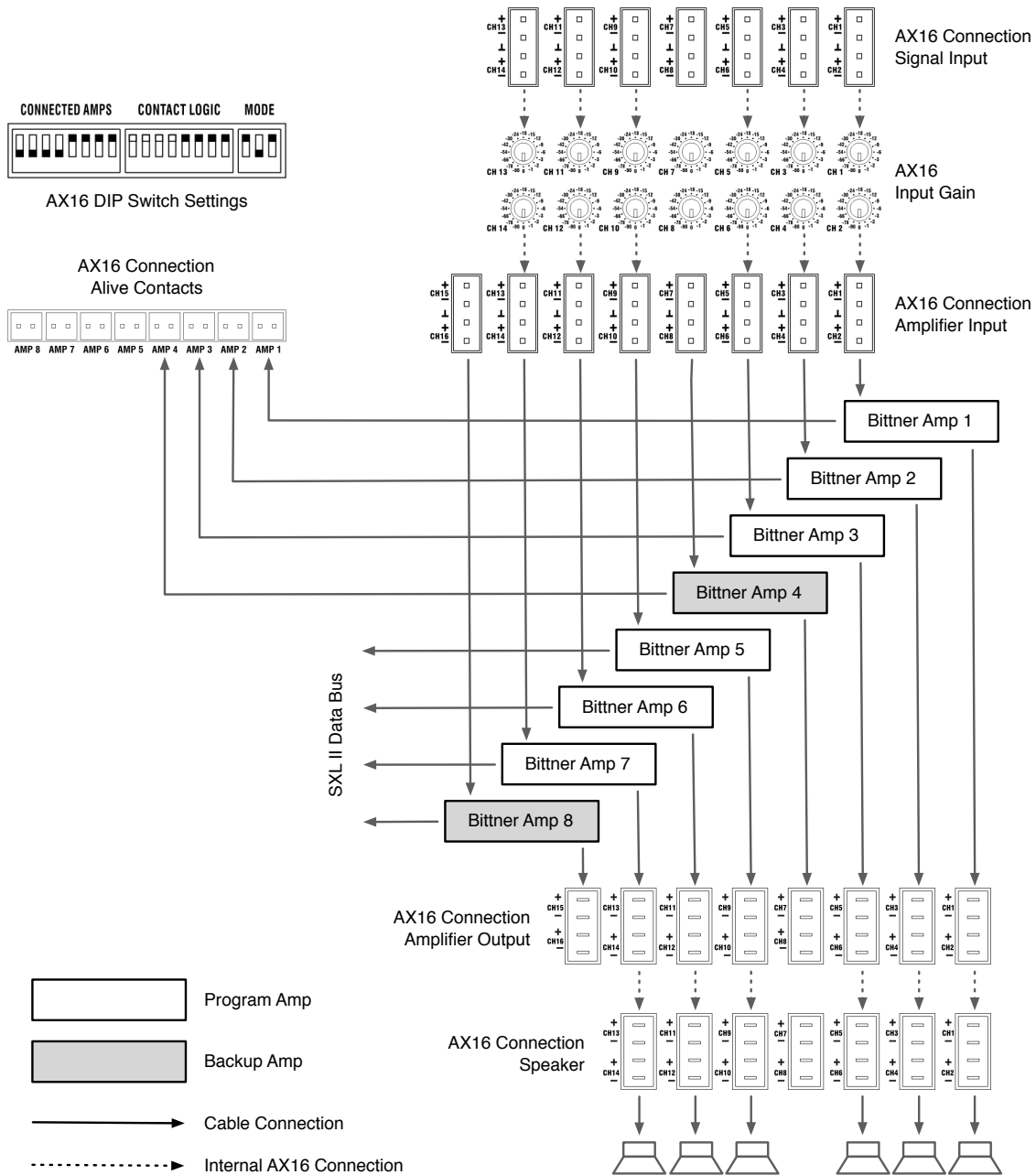

Figure 3.53: AX16 - Mode 3+1 with SXL II and Alive Contacts

3.14.10.3 Mode 3+1 with 4 Channel Amplifiers and Alive Contacts

The example uses 4-channel amplifiers. All channels use one power supply. Therefore it is necessary to backup all 4 channel at one time. In other words: 4 backup channels are required.

This can be accomplished by connecting only 2 channels of the amp to a 3+1 group of the AX16. In the diagram the channel 1+2 are indicated as “a” and the channels 3+4 as “b”. The backup amplifier is number 4.

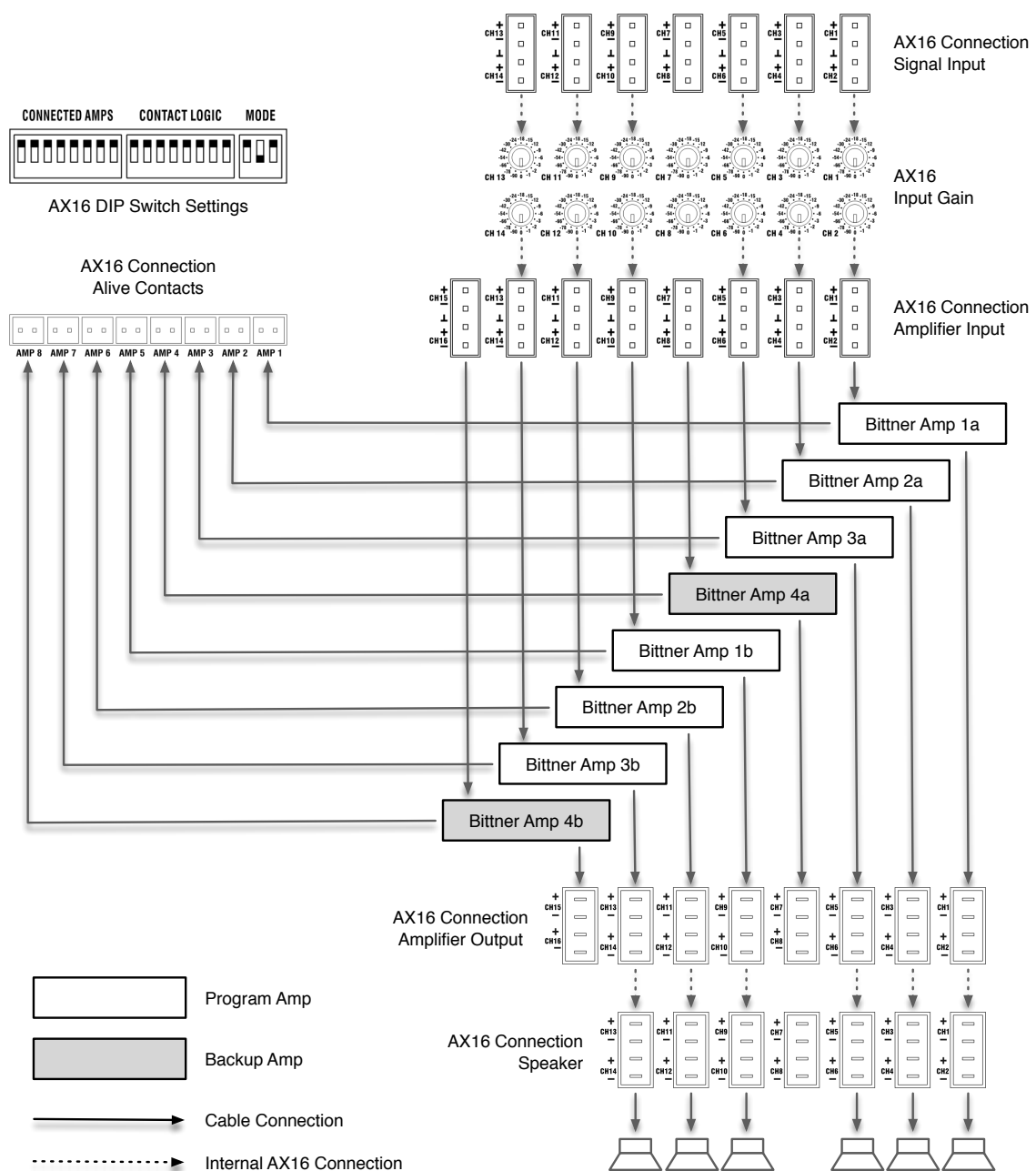

Figure 3.54: AX16 - Mode 3+1 with 4 Channel Amplifiers and Alive Contacts

3.15 SXL II - Control Interface

3.15.1 General Information

SXL II is the center piece for power management, amplifier control and monitoring. It works embedded in a LAN network, over the internet, or as a stand-alone unit with front panel control.

Up to 16 amplifier channels may be connected to one SXL II. The 16 amplifier channels may be freely combined of two-, four- and eight-channel amplifiers. The amplifiers are connected to the SXL II with the I²C or RS-485 system bus.

The SXL II is not only used to control the amplifiers but to provide an unparalleled level of monitoring. The control side of it will power up the amplifiers, control the volume, etc. The monitoring, however, will inform about the current status of the amplifier or individual channels (e.g. temperature, etc.). In addition, the SXL II provides full control of all features of the DSP incorporated into the XR-series.

Up to 16 complex scenarios (snapshots) may be recalled via the 8 logic inputs.

Its 8 output relays may be used for the signalization of errors or the control of external devices.

Two additional relays enable the control of external devices or scheduled applications like line monitoring, etc.

The SXL II offers extensive protocols for various events: for uninterrupted control, all relevant events are being stored and available over the Internet as Syslog and/or e-mail.

The internal signal generator allows for a scheduled, repetitive surveillance of the connected speaker lines.

3.15.2 Features

- Network management
- Integration into Ethernet LAN
- Communication with amplifiers via RS-485 or I²C
- Independent backup modes
- Local configuration without the need for a computer
- SD card for storage of configurations
- Logging of all events
- Forwards log-events via e-Mail and SNMP syslog
- Integrated web server
- Fast dynamic user configurable web interface with integrated help system
- Automatic detection of connected amplifiers
- Monitoring of voltage and current
- Logic inputs 5 - 24 volts
- Logic relay outputs
- Alive contact
- Display of active configuration, alive and status LED

3.15.3 Front and Rear View

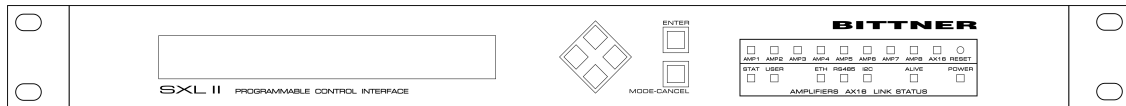

Figure 3.55: SXL II - Front View

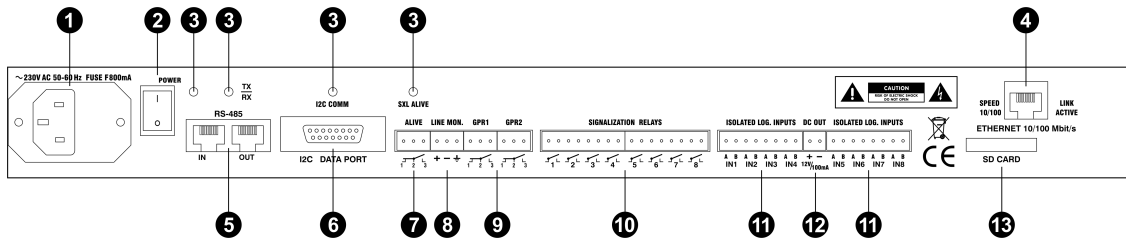

Figure 3.56: SXL II - Rear View

Connectors and Controls of the rear panel	Reference
1 Pluggable Mains Cord	
1 Fuse Mains Supply	
2 Mains Power Switch	
3 LED Power On	section 3.15.5
LED RS-485 Activity	section 3.15.5
LED I2C Activity	section 3.15.5
LED SXL II Alive	section 3.15.5
4 Ethernet Connector	section 3.15.4.1
5 RS-485 Data Port	section 3.15.4.2
6 I2C Data Port	section 3.15.4.2
7 Alive Contact	section 2.10
8 Audio Output Signal Generator	section 3.15.6.4
9 General Purpose Relay Outputs	section 3.15.6.3
10 Relay Outputs Signalization	section 3.15.6.2
11 Logical Inputs	section 3.15.6.1
12 Auxiliary Voltage	section 3.15.6.1
13 SD Card Slot	section 3.15.10

3.15.4 Starting Up

3.15.4.1 Network Connection

The SXL II communicates via Ethernet. An unlimited number of SXL II units may be connected to an Ethernet network. The SXL II establishes the communication with local devices (amplifiers, backup switches, etc.). It communicates via the LAN with the control computer or media control system. A standard RJ-45 connector (CAT5), located on the back panel of the device, interfaces with the Ethernet network.

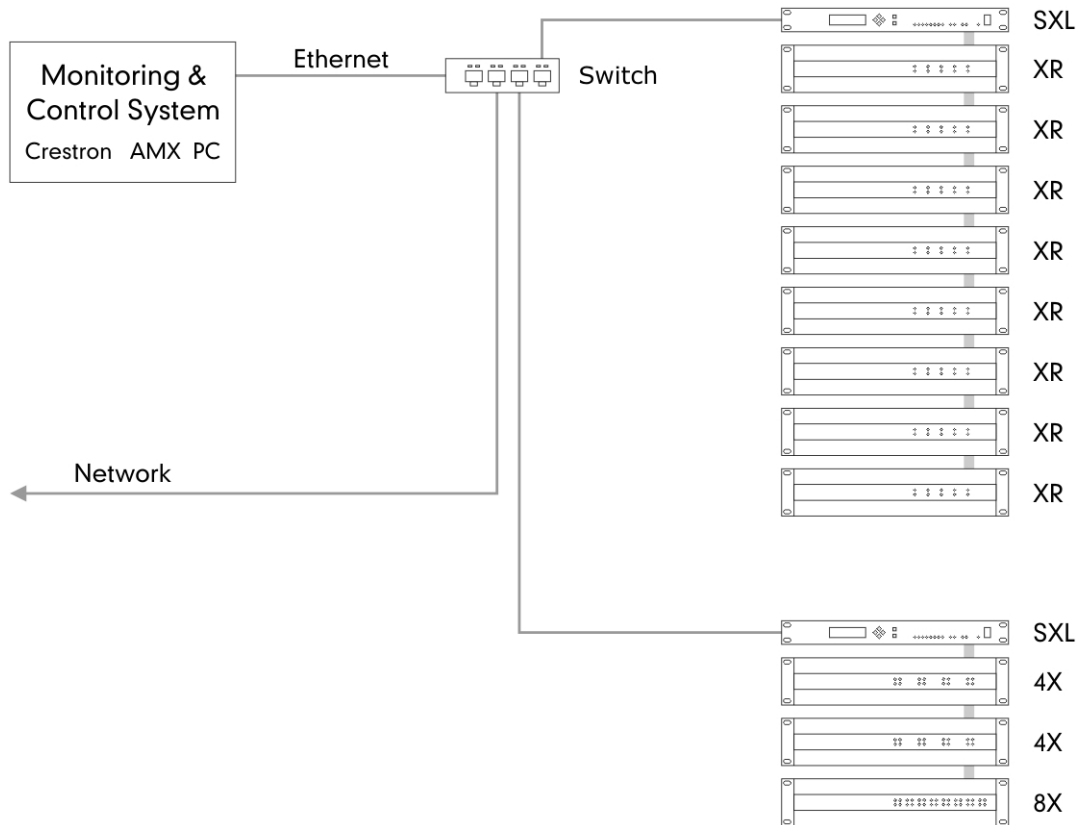

Figure 3.57: SXL II - Integration in an Ethernet network



Caution

The SXL unit works with 10/100 Mbps (you might have to reconfigure your PC). In the case your computer does not support 10/100 Mbps, it is recommended to connect to an Ethernet switch that supports both data rates.



Figure 3.58: SXL II - Ethernet Connector

3.15.4.2 Connection of the Amplifiers and the AX16

The AX16 can be connected via I²C or RS-485, depending on the available amplifier interface (refer to Data Port ([section 2.12](#))).

I²C System Bus The units are connected with a 15-pin ribbon cable. It is equipped with male Sub-D DB-15 connectors. One connector is required for each amplifier, the AX16 and the SXL II.



Figure 3.59: SXL II - I²C System Bus Cable

The I²C system bus transmits the following signals:

- Control signals in I²C format (refer to [section 2.12.1](#))
- Audio of the emergency paging bus (only XR Series, see [section 3.3.6](#))
- Audio of the monitor bus (only XR Series, siehe [section 3.3.6](#))
- 12V supply voltage for the interface boards of the amplifiers and the AX16 (see [section 2.12.1](#))

The maximum cable length is 2 meters. The devices need to be installed in such a way as to not exceed the maximum cable length.

Preassembled cables or ribbon cables and single connectors may be ordered from your supplier.

RS-485 System Bus An “off the shelf” CAT5 patch cable may be used.

For the pin layout of the RS-485 connector please refer to [section 2.12.2](#).

3.15.4.3 Address IDs

A unique ID needs to be assigned to every amplifier that is connected to an SXL II via the system bus. It may be set via the DIP switch on the backside of the amplifier.

Every two channels of an amplifier share one ID. Consequently, every two-channel amplifier uses one ID, four-channel amplifiers two IDs and eight-channel amplifiers four IDs. The table explains the different settings.

Number of the Amplifier's Channels		
2	4	8
ID 1	IDs 1+2	IDs 1+2+3+4
ID 2		
ID 3	IDs 3+4	
ID 4		
ID 5	IDs 5+6	IDs 5+6+7+8
ID 6		
ID 7	IDs 7+8	
ID 8		



Caution

After setting the ID(s), the amplifier needs to be disconnected from the SXL (system bus cable) and from the mains supply (power cord) to activate the new ID.

3.15.4.4 Settings of Network Parameters

To operate the SXL II in an Ethernet network, the network settings need to be set. The settings may be changed manually via the front panel. To avoid inadvertent changes, these network parameters are only accessible via *SERVICE MODE 1* (refer to [section 3.15.7.2](#)).

Pushing the *UP* and *DOWN* keys at the same time will set the SXL II into *SM1*. *!sm1* will light up in the upper right space of the display. By pushing the *RIGHT* or *LEFT* key, the *SXLSTAT* menu group may be selected. Select the appropriate parameters by pushing the *UP* and *DOWN* keys. The parameters that may be set are IP address *IP* and subnet mask *MS*.

Push *UP* and *DOWN* keys until *IP* lights up in the lower left space of the display.

To change this parameter, push *ENTER*. Square brackets indicate that the parameter value may now be set by pushing the *UP* and *DOWN* keys. To change the next number of the IP address, push the *RIGHT* button. After having set all four IP address blocks, pushing *ENTER* once again will save the new settings.

The *UP* key will open the parameter *MS* (subnet mask) that may be changed accordingly.



Caution

The SXL II needs to be power cycled after changing and saving the network settings. After power-up it automatically starts in the *USER MODE*.

3.15.5 LED Indicators

The SXL II is equipped with 12 LEDs on the front panel:



Figure 3.60: SXL II - LED Indicators Front Side

LED	Color	Function
AMP1...AMP8, AX16	9x red	Indicates an existing connection with the amplifiers via data port (Online Status). Each LED represents 2 channels of one amplifier (equivalent to the IDs). A blinking LED indicates an error.
STAT	1x red	Indicates the status of the SXL II. A once-a-second heartbeat indicates normal operation.
USER	1x green	This LED is freely programmable via Ethernet and may be used as readout of any condition. As a special function, it may light up while data are being stored on the internal flash disk (refer to Permanent Backup of Operation Modes (section 3.15.9.6)).
ETH	1x green	Indicates connection of the SXL II to the Ethernet network
RS-485, I ² C	2x red	Indicates normal operation of the system bus
ALIVE	1x green	Indicates normal operation of the SXL II
POWER	1x green	The SXL II is powered up

The SXL II is equipped with 4 LEDs on the rear panel:



Figure 3.61: SXL II - LED Indicators Rear Side

LED	Color	Function
TX-RX, I ² C COMM	2x green	Indicates activity on the system bus
SXL ALIVE	1x green	Indicates normal operation of the SXL II
POWER	1x green	The SXL II is powered up

3.15.6 Special Ports

3.15.6.1 Logical Inputs

The SXL is equipped with 8 voltage inputs. A DC voltage below 5V is interpreted as a logical 0, DC voltages between 5V and 24 as a logical 1. The interpretation is polarity independent, i.e. the + and – poles may be connected arbitrarily.



Figure 3.62: SXL II - Logical Inputs

The logical inputs may be used for the following applications:

- Recall of the 16 internal configurations
- Readout via Ethernet (e.g. conditions inside the rack, etc.)



Caution

The SXL II provides an auxiliary voltage (12V/100mA) for an easy connection of potential-free contact closures.

3.15.6.2 Signalization Relays

The SXL II offers 8 Signalization Relay Outputs, which are controlled by the Error Matrix (siehe Error Matrix ([section 3.15.9.2](#))).

The relays are normally closed and open in case of a fault indication.



Figure 3.63: SXL II - Signalization Relay Outputs of the Error Matrix

3.15.6.3 General Purpose Relays

The SXL II comes with two general purpose relays (GPR1 und GPR2), which may be used in the open, closed or toggle mode. They feature a switching capacity of 125 VAC /110 VDC at 0,3 A max.

Each relay offers 3 pins labeled 1, 2 and 3. Pin 2 is the joint root. If the relay is activated, pins 2 and 3 are connected. Otherwise, pins 1 and 2.



Figure 3.64: SXL II - GPR Relay Outputs

The relay offers various uses:

- Recall of arbitrary switching configurations via the 16 internal configurations
- Switching of time controlled operations e.g. line monitoring (refer to [section 3.15.9.3](#))
- Control via the Ethernet (e.g. to allow for remote controlled switching inside the rack via Ethernet)

3.15.6.4 Signal Generator

The SXL II is equipped with a configurable signal generator.

Its audio signal is available through the output *LINE MON* (electronically balanced, signal(+), signal(-) and shield).

The signal generator may be used for impedance measurements in configurable time intervals (refer to [section 3.15.9.3](#)).



Figure 3.65: SXL II - Signal Generator Output

3.15.7 Manual Operation

The SXL II may be locally controlled using the front panel keypad incl. arrow keys. All parameters can be accessed and are displayed on the two-line LCD with 20 digits each.



Figure 3.66: SXL II - LCD and Front Panel Control

The LCD is divided into three sections:

Section	Function
Line 1 – links	Menu (refer to section 3.15.7.1)
Line 1 – rechts	Mode information (refer to section 3.15.7.2)
Line 2	Parameters and their values (refer to section 3.15.7.1)

Example:

```
-----
CHAN.2                rw
#Gain= -19.5dB
-----
```

Explanation: The SXL II is in the *CHAN* menu, channel 2 is selected. The channel volume is set to -19,5 dB. The symbol # in front of the parameter indicates that it is user controllable. The abbreviation *rw* indicates the current entry mode.

3.15.7.1 Menus & Parameters

The menu items and their parameters are selected with the arrow keys:

- Use the keys *LEFT* and *RIGHT* to select the menu items
- Use the keys *UP* and *DOWN* to select the parameters of the menu items

The reduced size of the display requires abbreviations. Their meanings are:

Abbreviation	Meaning
AMP.1 to AMP.8	Parameter per amplifier (e.g. Standby)
CHAN.1 to CHAN.16	Parameter per channel (e.g. Gain)
LINPUTS	Logical inputs
RELAYS	Relay outputs
SXLSTAT	Date & time, network settings
MONITOR	Monitor bus
DIAG	Function of the USER LED
CONFIG	Configuration
MATRIX	Error matrix
AX16	Parameters of the AX16

A parameter may be changed by selecting it and pushing *ENTER*. The value will appear in brackets, e.g. *#Standby=[ON]*. It may now be changed by using the *UP* and *DOWN* keys. If a large value range needs to be changed (e.g. volume), holding the key down will speed it up. Push *ENTER* to finalize the setting, *CANCEL* to abandon the changes.

User controllable parameters are indicated by a hash (#), e.g. *#Standby=ON* (refer to [section 3.15.7.2](#)).



Caution

If a connected amplifier is not featuring a certain parameter, the parameter will not be displayed.

3.15.7.2 Entry & Service Modes

In the first line's right corner of the LCD, more information is displayed with 4 symbols.

Entry Mode The entry mode defines how the parameters are displayed and edited. It may be selected by repeatedly pushing the *MODE* key:

- *<w1>* only indicates the writable, respectively the controllable parameters (*w* = write). 1 means that only the currently addressed amplifier/channel may be altered.
- *<w2>* is similar to *w1* but will also set the parameters of the associated stereo channel. The menu items are accordingly displayed, e.g. *CHAN.3+4*.
- *<w*>* is similar to *w1* but the asterisk (*) represents all amplifiers/channels. In this mode, for example, all amplifiers may be set to standby at the same time or set mute at the same time.
- *<rw>* is similar to *w1* but additionally, all values, including the read only conditions are displayed, e.g. *ACStatus* (= mains supply) of an amplifier, etc.

Service Mode The two following Service Mode Levels are used to protect parameters from accidental changes.

- !sm1

Service Mode Level 1 - will be started by pushing the keys *UP* and *DOWN* at the same time. The following parameters may then be changed:

- Network settings (refer to [section 3.15.4.4](#))
- Delay time when a configurations is re-called via the logic inputs (refer to [section 3.15.9.1](#))
- Continuous storage the SXL's current condition to the intern flash disk ON/OFF (refer to [section 3.15.9.6](#))

- !sm2

Service Mode Level 2 – will be started by pushing the keys *UP* and *DOWN* at the same time, followed by simultaneously pushing keys *LEFT* and *RIGHT*. The following parameters may then be changed:

- Toggle between manual and automatic confirmation of an error ON/OFF (refer to [section 3.15.9.4](#))

To use the web interface, it is necessary to:

- Connect it to a PC (directly or via an Ethernet network)
- Run a common web browser (Internet Explorer, Firefox, Safari, etc.)
- Know the IP address of the SXL

Please follow the instructions below to activate the web interface:

- Open the web browser
- Enter the IP address of the SXL in the address line of the browser (press *ENTER*)
- A login mask appears. Register and finish with *SUBMIT*.



Caution

The default login is:

Name: sxl

Password: 11111

Do not use caps for the name. The password is five times the figure “one”.

Basically, working with the web interface takes this approach: Parameters to be changed need to be entered into the appropriate form field. Then, the new values need to be transmitted to the SXL II. This may be achieved by using the appropriate button: Set, Save, Recall or Show.



Caution

Parameters not available for a specific amplifier model are greyed out and cannot be changed.

In the following, the various web pages will be specified.

3.15.8.1 Status

This is a status page only and provides an overview over the condition of the SXL II and the connected amplifiers.

As on every page of this web interface, the navigation menu to access the different functions of the SXL II is located at the top. Its IP address and name are also displayed.

SXL_II	192.168.168.83
Firmware Revision: 4.65	Run Time: 5 days, 6 hours, 16 minutes, 54 seconds
	Free Memory: 741376 bytes

[Home](#) [Status](#) [Settings](#) [Monitoring](#) [Signalization](#) [Configurations](#) [AX16](#) [Misc](#) [Log](#) [Help](#)

Figure 3.68: SXL II - Web Interface: Header

The main part of the page indicates the condition of the amplifiers/channels (4 or 8 channel amplifiers will be represented as a block) and the AX16 (if present).

The right sidebar shows two sections:

- Log with the last 5 entries
- Configurations (Status, Recall and Save)

The tab *Status* shows a double arrow. It is being used to extend the main part of the display to show more parameters of the amplifier.



Figure 3.69: SXL II - Web Interface: Expand Arrows

3.15.8.2 Settings

This page provides access to all parameters of one amplifier and its channels.



Caution

Parameters not available for a specific amplifier model are grayed out.

The tab *Settings* shows a double arrow. It is being used to extend the main part of the display to show more parameters of the amplifier.

Parameter	Function
Standby	Standby On/Off
Power On Delay	A delay may be set before powering up the amplifier after receiving the command
In1 and In2*	These level values (-90 to +6 dB in 0.5 dB steps) and the level values of the neighboring channel form a 2 by 2 mixer. It may be used for mixing of both channels.
Gain	Output level (-90 to +6 dB in 0.5 dB steps)
Mute	Channel mute On/Off
Inv*	Phase shift of 180 degrees
DSP	Access to the DSP settings of a channel

* Available only for specific models

3.15.8.3 DSP

The DSP page offers all parameters and the option to save and recall up to 50 configurations. The configurations may be labeled for easier identification.

Each DSP configuration consists of the following:

- 10-Band parametric EQ
- Limiter and Compressor
- Noise Gate
- Delay
- Low und Highpass Filter (Crossover)

The dropdown menu *Display Channel* in the segment *Settings* allows for the selection and display of the DSP settings.

Settings																	
Display channel 1 - [dropdown]																	
Apply displayed settings	Device	EQ <input checked="" type="checkbox"/>	DYN <input checked="" type="checkbox"/>	NG <input checked="" type="checkbox"/>	XO <input checked="" type="checkbox"/>	DLY <input checked="" type="checkbox"/>											
	Channel	1 <input checked="" type="checkbox"/>	2 <input type="checkbox"/>	3 <input type="checkbox"/>	4 <input type="checkbox"/>	5 <input type="checkbox"/>	6 <input type="checkbox"/>	7 <input type="checkbox"/>	8 <input type="checkbox"/>	9 <input type="checkbox"/>	10 <input type="checkbox"/>	11 <input type="checkbox"/>	12 <input type="checkbox"/>	13 <input type="checkbox"/>	14 <input type="checkbox"/>	15 <input type="checkbox"/>	16 <input type="checkbox"/>

Figure 3.70: SXL II - Web Interface: Copy of DSP Settings

In addition the *Settings* segment provides a comfortable way to copy and paste all or only selected DSP settings between amplifier channels:

1. Select the channel to be copied. Alternatively all displayed DSP settings are being copied.
2. *Device* will select the DSP functions by clicking into the check box. To copy only the EQ settings for example, only the check box *EQ* is selected.
3. *Channel* selects the destination(s) with the 16 check boxes.
4. Clicking the *Set* button will copy the selected settings.

3.15.8.4 Monitoring

This page consists of three sections.

Signal Generator The pilot tone generator works with an adjustable frequency between 19 and 22.5 kHz. The output level can be freely adjusted.

Two parameters set the intervals:

Parameter	Function
Period of check	Total duration of deactivation and operation
Duration of tone	Active time

Line Monitoring Generator			
Activated	<input checked="" type="checkbox"/>		
Period of check [s]	100	Tone frequency [kHz]	20.0 [dropdown]
Duration of tone [s]	10	Tone level [dBu]	-20
			[Set]

Figure 3.71: SXL II - Web Interface: Signal Generator



Caution

It is possible to switch relay GPR 1 or GPR 2 in the selected interval. This allows for the use of an external signal generator (refer to Line Monitoring (section 3.15.9.3)).

Monitored Channels The channels to be monitored have to be selected.

Monitored Channels																		
Channel	1	2	3	4	5	6	7	8	9	10	11	12	13	14	15	16	Set	
Select	<input type="checkbox"/>	<input type="checkbox"/>	<input type="checkbox"/>	<input type="checkbox"/>	<input type="checkbox"/>	<input type="checkbox"/>	<input type="checkbox"/>	<input type="checkbox"/>	<input type="checkbox"/>	<input type="checkbox"/>	<input type="checkbox"/>	<input type="checkbox"/>	<input type="checkbox"/>	<input type="checkbox"/>	<input type="checkbox"/>	<input type="checkbox"/>		
Line Status	OK	OK	OK	OK	OK	OK	OK	OK	OK	OK	OK	OK	OK	OK	OK	OK		

Figure 3.72: SXL II - Web Interface: Monitored Channels

Load Impedance Window Every monitored channel will be displayed in a dedicated window.

Load Impedance Window								
Channel	1	2	3	4	5	6	7	8
Short Threshold [Ω]	1.0	1.0	1.0	1.0	1.0	1.0	1.0	1.0
Open Threshold [Ω]	40.0	40.0	40.0	40.0	40.0	40.0	40.0	40.0
Load Status	OK	OK	OK	OK	OK	OK	OK	OK

Figure 3.73: SXL II - Web Interface: Load Impedance Window

Parameter	Function
Short Threshold	Indicates the lowest value of the window for impedance measurement. Values below this value are interpreted as a short-circuit.
Open Threshold	Indicates the highest value of the window for impedance measurement. Values above this value are interpreted as opened output.

3.15.8.5 Signalization

This page consists of two sections.

Error Matrix The 8 signalization relays may be assigned as fault indication contacts, using the Error Matrix. In this indication concept, each relay may be assigned to a certain type of defect/problem of any connected amplifier. A general fault indication is generated if all types of defect are assigned to one relay.

Error Matrix										
Relays	1	2	3	4	5	6	7	8	Set	
ACStatus	<input checked="" type="checkbox"/>	<input type="checkbox"/>	<input type="checkbox"/>	<input type="checkbox"/>	<input type="checkbox"/>	<input type="checkbox"/>	<input type="checkbox"/>	<input type="checkbox"/>		
Protect	<input type="checkbox"/>	<input checked="" type="checkbox"/>	<input type="checkbox"/>	<input type="checkbox"/>	<input type="checkbox"/>	<input type="checkbox"/>	<input type="checkbox"/>	<input type="checkbox"/>		
Line Monitor	<input type="checkbox"/>	<input type="checkbox"/>	<input checked="" type="checkbox"/>	<input type="checkbox"/>	<input type="checkbox"/>	<input type="checkbox"/>	<input type="checkbox"/>	<input type="checkbox"/>		
Load Short	<input type="checkbox"/>	<input type="checkbox"/>	<input checked="" type="checkbox"/>	<input type="checkbox"/>	<input type="checkbox"/>	<input type="checkbox"/>	<input type="checkbox"/>	<input type="checkbox"/>		
Load Open	<input type="checkbox"/>	<input type="checkbox"/>	<input checked="" type="checkbox"/>	<input type="checkbox"/>	<input type="checkbox"/>	<input type="checkbox"/>	<input type="checkbox"/>	<input type="checkbox"/>		
Overheat	<input checked="" type="checkbox"/>	<input type="checkbox"/>	<input type="checkbox"/>	<input type="checkbox"/>	<input type="checkbox"/>	<input type="checkbox"/>	<input type="checkbox"/>	<input type="checkbox"/>		
Offline	<input checked="" type="checkbox"/>	<input type="checkbox"/>	<input type="checkbox"/>	<input type="checkbox"/>	<input type="checkbox"/>	<input type="checkbox"/>	<input type="checkbox"/>	<input type="checkbox"/>		
Status	ON	ON	ON	ON	ON	ON	ON	ON		

Figure 3.74: SXL II - Web Interface: Error Matrix

Example: In the illustration above, the fault indication contacts have been assigned to logical groups. Relay 1 indicates defects of the amplifier as a whole. Relay 2 is activated by channel based defects, relay 3 signalizes impedance problems.

General Purpose Relays The conditions for activating the GPRs are user definable (manually or via Ethernet) and may be saved in a configuration.



Caution

It is possible to switch relay GPR 1 or GPR 2 in the selected interval. This allows for the use of an external signal generator (refer to Line Monitoring ([section 3.15.9.3](#))).

3.15.8.6 Configurations

The SXL II offers the option to save up to 16 configurations. This includes all parameters of the SXL II and all devices connected to the system bus. The configurations may be labeled for easier identification.

This page also provides status information and additional functions.

Function	Description
Current SXL II Configuration	Indicates the current SXL II configuration and its name
Result of last recall	Status result of the last operation (save or recall of a configuration)
Default Configuration	Configuration that is re-called at the start-up of the SXL II
Delete Configuration	<i>Defined</i> shows the stored configurations. <i>Delete</i> selects the configurations to be deleted.
Direct Control (binary)	This function enables the re-calling of SXL II configurations via using the first four logical inputs (refer to section 3.15.9.1).
Direct Control (single)	Each of the eight logic inputs can be assigned to recall a configuration directly (refer to section 3.15.9.1).

The SXL II powers up with the saved data of a configuration. If no configuration has been set for the start-up, configuration 0 will be the default. This default configuration has a special status and is administrated by the SXL II. Depending on setting, configuration 0 is made up of following data:

- A. A copy of the lastly re-called configuration 1 to 16
- B. The current condition of all parameters

Point A is important if the configurations are re-called by the logic inputs (refer to [section 3.15.9.1](#)). Point B is a special function, explained under “Permanent Backup of Operation Modes” (refer to [section 3.15.9.6](#)).



Caution

Since the SXL II may overwrite data in configuration 0, it should not be used for storing user settings.

3.15.8.7 AX16

The AX16 device is an intelligent amplifier switching unit that may also be connected to the SXL II via its system bus. Together, both devices form a powerful solution to guarantee a failure-free operation.

The AX16 web interface page offers mainly status information. Practically all settings are made with DIP switches on the back panel (refer to [section 3.14.5](#)). These settings are evaluated by the SXL II which takes over control of the AX16 in case of amplifier error.

AX16 shows a double arrow on its right side. It is being used to extend the main part of the display of the parameters.

The block diagram and its corresponding tabel display the functions of the individual amplifiers, depending on the selected mode of the AX16.

Status		Amp	Backup
Online	YES	1	8
Alive	YES	2	8
Control Mode	SXL II	3	8
Backup Mode	7+1	4	8
Num of Amp fails	0	5	8
Last failed Amp	None	6	8
		7	8
		8	---

Figure 3.75: SXL II - Web Interface: Status Information

The controllable parameters are located at the lower part of the page:

Function	Description
Use AX16	Defines which amplifiers are part of the backup switching.
Force Amp error	For testing purposes, an error may be simulated for the specified amplifier(s).
Copy settings to backup before switch	If an amplifier fails, its settings will be transferred to the backup amplifier.
Split mode	Activates a mode that allows the use of amplifiers with or without SXL II dataport to be used with an AX16 (refer to section 3.15.9.5).
4X/8X cross routing	Allows for the use of 4- and 8-channel amplifiers with the AX16 (refer to section 3.15.9.5).

Copying all settings to the backup amplifier is a unique Bittner Audio feature and should always be activated. If the faulty amplifier and the backup amplifier are of the same model, all settings will be transmitted 1 to 1. This procedure and the following switch-over will be completed after 250ms.

The copying includes all settings that are provided by the backup amplifier. In any case, the system will try to maintain the same volume. To achieve this, the SXL II “translates” the level settings of the different amplifiers. This feature allows for the replacement of defective amplifiers by models of different power, for example a XR1500 with a XR4000!



Caution

The copying of all settings to the backup amplifier is a unique Bittner Audio feature and will not work with models of third-party suppliers.

3.15.8.8 Misc

Some function blocks of the SXL II have been combined on this page. They are global settings for the SXL II and will be explained in the following sections.

Network Settings *Network Settings* shows the active network parameters.

The Parameter *Authorised IP* is a subnet mask, which may be used to grant only a certain range of IP addresses access to the SXL II.



Caution

Please contact your network administrator for the correct values of above parameters.

Syslog The SXL II records every important event on its intern flash disk (refer to [section 3.15.8.9](#)). To obtain more security, these record files may be mirrored via Syslog to any Host or IP address in the network and recorded there.

This also applies to other SXL II within the network. It allows to display the logbooks of all SXL II on a “Master SXL II” by registering the IP address of the master.



Caution

Several free Syslog programs respectively deamons are available for Windows. Kiwi Enterprises, for example, (<http://www.kiwisyslog.com>) is a well-known supplier.

Email/SMTP SMTP stands for Simple Mail Transfer Protocol. The SXL II is able, via an appropriate gateway in the network, to send logbook entries as emails.

To ensure trouble-free transmission of the data, the following parameters need to be set:

Function	Description
Email from	Sender's address
Email to	Recipient's email address
SMTP Server	Gateway Address



Caution

Please contact your network administrator for the correct values of above parameters.

User LED The *User LED* may be utilized to signal any condition of the system. Using the control over Ethernet can be used to manually switch the LED to identify a dedicated SXL II in a Rack.

The *User LED* may also indicate recording data on the internal flash disk (refer to Permanent Backup of Operation Modes ([section 3.15.9.6](#))).

Re-start The SXL II may be re-started from the web interface. This feature is very useful after upgrading the firmware via the network (refer to [section 3.15.10.2](#)).

To re-start, set the checkmark and click *Set*.

Login Data Username and Password may be changed arbitrarily.

Device and Channel Labels For a better identification, the SXL II and the amplifiers may be labeled.

3.15.8.9 Log

The SXL II logs every important event on its internal flash disk. The amount of recordable events is about 13000.

The SXL works with the Syslog Protocol (refer to [section 3.15.8.8](#)). This protocol subdivides the events into priorities:

Priority
Emergency
Alert
Critical
Error
Warning
Notice
Info

Filter

The amount of the logbook entries may be recalled according to these priorities. In addition, all entries may be limited to a certain amount of time.

The Parameter *IP to show* is a subnet mask. It filters the readout to show only SXL II units belonging to a certain range of IP addresses.

Message

It is possible to store user messages (max. of 70 characters) in the log. This is useful for instance, to note the start and end of maintenance work.

Export

For storage reasons, the logbook may be copied to a control computer from the flash disk of the SXL II.

3.15.8.10 Home

Home gives an overview of all available SXL II in a system, indicating IP address, name and status. It is also possible to navigate to the different pages of an SXL II.



Caution

Status refers only to the condition of the SXL II. It will not show the condition of an amplifier.

3.15.9 Special Functions

3.15.9.1 Configuration Switching via the Logic Inputs

The configurations of the SXL II may be also re-called via its logic inputs. This provides, for example, external control without a network connection.

Switching by the logical inputs is globally activated for the SXL II. The appropriate parameter *CfgByInput* is located in menu *SXLSTAT* and should be switched *ON*.

If the switching should be controlled by a mechanical multi-switch, it is important to note that the contacts may bounce electrically. This effect is typical for elastic components inside switching mechanisms. As a result, the SXL II may switch several times between two configurations.

The parameter *CfgDelay* in the *SXLSTAT* menu is used to avoid this negative effect. It is accessible in Service Mode 1 (refer to [section 3.15.7.2](#)). It defines how long the control voltages need to be applied until it is recognized by the SXL II. The delay is set by numbers between 2 and 20. These numbers need to be multiplied by 100 ms. Consequently the values range from 200 ms to 2 seconds. A value of 5 (= 500 ms) has proven to be adequate.

Binary Switching The voltages applied to the first 4 logic inputs are interpreted as a 4-Bit word:

Configuration	IN 4	IN 3	IN 2	IN 1
1	0	0	0	1
2	0	0	1	0
3	0	0	1	1
4	0	1	0	0
5	0	1	0	1
6	0	1	1	0
7	0	1	1	1
8	1	0	0	0
9	1	0	0	1
10	1	0	1	0
11	1	0	1	1
12	1	1	0	0
13	1	1	0	1
14	1	1	1	0
15	1	1	1	1



Caution

The bit-word 0000 is not listed as it is being used for a different purpose (see below).

To re-call a configuration, it makes no difference whether the applied bit-word is permanently or momentarily applied. In the latter case the appropriate SXL II configuration will be re-called and then configuration 0, which always holds a copy of the last re-called configuration (refer to [section 3.15.8.6](#)).

Example: To re-call configuration 11, the bit muster 1011 should be applied to the logic inputs. The SXL II will start configuration 11. The contents of configuration 11 will then be copied to configuration 0. After disconnecting the control voltages, the SXL II switches to configuration 0 which is now identical to configuration 11.

Direct Switching The eight logic inputs may be used to directly recall a configuration. It is irrelevant how long the control voltage is applied to the input.

3.15.9.2 Error Matrix

In the case that the SXL II is not integrated into a network, it is still possible to provide an error indication. The error matrix offers 8 fault indication contacts. Every relay may be allocated to a certain type of defect.

Type of Defect	Description
AC Status	Mains fuse or mains supply failure
Protect	Amplifier channel in protect mode
Line Monitor*	Impedance measurement could not be accomplished
Load Short*	Impedance below lower limit
Load Open*	Impedance above upper limit
Overheat*	Critical temperature
Offline	Amplifier does not answer via data bus

* This function is available for certain devices only

The allocation of the relays applies to all connected amplifiers. In case of a defect, the 8 LEDs on the front of the SXL II ([section 3.15.5](#)) will indicate which amplifier is affected.

Although, the 8 relays may be programmed to indicate different types of defects (refer to [section 3.15.8.5](#)), a general default indication is usually required instead. This may be created by allocating all types of defect to one relay only.

It is also possible to combine the error matrices of several SXL II. To achieve this, every SXL II is set to the same relay allocation. The relays of each SXL II are then either wired in series (released contacts).



Caution

“Released relay contacts in case of defect” are the regular case in installations. The SXL II works accordingly: In case of error-free operation of the connected amplifiers, the relays are active. In case of an error (including a failure of the mains supply of the SXL II) all relays release.

3.15.9.3 Line Monitoring

The SXL II may be used as a low impedance line monitoring device together with appropriately equipped Bittner Audio amplifiers. If required, the measurements may be accomplished in intervals less than 100 seconds to provide full compliance with EN-60849.

The following functions and parameters are involved in the line monitoring (also refer to [section 3.15.8.4](#)):

- Signal Generator
- Parameter *LoadSigChk* per amplifier channel
- Parameter *Short Threshold* and *Open Threshold* for impedance window

The following illustration shows the principal lay-out. The diagram shows an uninterrupted monitoring of the audio path in compliance with the EN-60849:

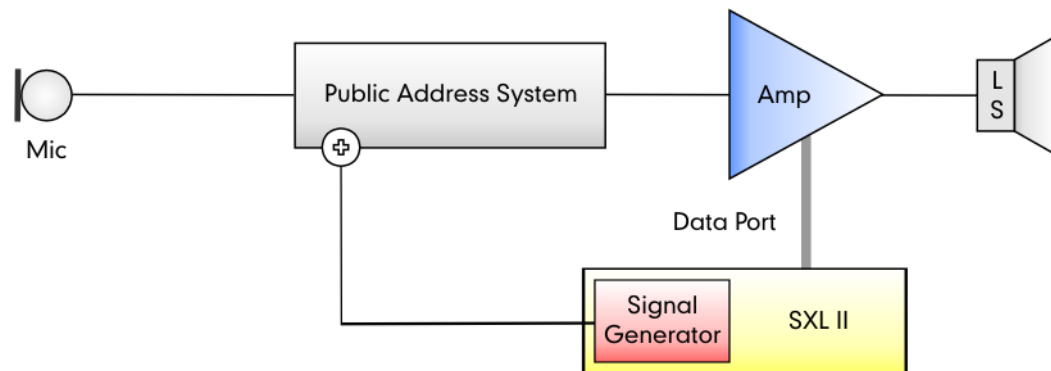

Figure 3.76: SXL II - Line Monitoring

The paging system is responsible for the monitoring from microphone capsule to its own inputs, whereas the SXL II monitors the rest of the audio chain. Every 90 seconds the signal generator switches a 20 kHz pilot tone for 10 seconds to the transmission chain. During the 10 seconds, the SXL II measures the impedance of the amplifier channels of interest (parameter *LoadSigChk*). In the case that the measured value is not within the impedance window, an error will be displayed.

To ensure a reliable measurement, a sufficiently high output level is required. This level averages at about 1 to 2 Watts, depending on the amplifier model. Therefore, the line length and its corresponding losses are important.

At very low levels (close to the lower limit), the measurement taken during the first few minutes after turning on the amplifier may yield inaccurate results. To avoid misunderstandings, the system offers the parameter *LoadSig start after* to delay the first measurement after power-on. A value of 600 s (= 10 minutes) has proven to be adequate.

3.15.9.4 Error Acknowledgment

A possible amplifier problem will be indicated by a blinking *AMPLIFIER LINK STATUS LED* on the front panel of the SXL II (refer to [section 3.15.5](#)) and by a short description on the LCD (refer to [section 3.15.12](#)). In addition, the error is recorded to the logbook (refer to [section 3.15.8.9](#)).

To meet the safety requirements of today's installations, a detected error needs to be confirmed after its clearance. The confirmation results in two events:

- The SXL II tests whether the error has really been removed or still exists
- If the test has been successful, the verification will be recorded to the logbook

It is not possible to confirm an error via the network. Therefore, it is necessary to perform the following steps on the front panel of the device:

- After an error has been detected, the display of the SXL II enters the *ErrMatrix* menu automatically and shows the appropriate error codes under *LastErr* (refer to [section 3.15.12](#)).
- Pushing the *DOWN* key once will go to the parameter *ErrorClr*. Its value is *OFF*.
- Push *ENTER* and *UP* or *DOWN* to set its value to *ON*.
- Complete the setting with *ENTER*. The SXL II will automatically start the verification (this may take up to 10 seconds).
- In case the error has been removed, the *AMPLIFIER LINK STATUS LED* will permanently light up again.

This safety feature is certainly not needed in every installation. Therefore, it may be deactivated. The necessary parameter *ClrErrorAuto* in the menu *SXLSTAT* is only available after the activation of Service Mode 2 (refer to [section 3.15.7.2](#)).

**Caution**

If the confirmation of errors is deactivated, the SXL II will no longer be compliant with safety requirements. Therefore, it may be deactivated only in appropriate installations.

3.15.9.5 Backup Switching

The SXL II works seamlessly with the Bittner Audio Intelligent Backup Switch AX16. This device may be connected to the SXL II via the system bus. Combined, the two devices offer a powerful solution for uninterrupted operation.

In case of error of an amplifier, the SXL II is in direct control of the switching to the backup amplifier:

- The SXL II copies every setting of the defective amplifier to the backup amplifier
- The SXL II transmits the ID of the failed amplifier to the AX16
- The AX16 switches to the backup amplifier

This whole procedure will take only 250ms.

If the defective amplifier and the backup amplifier are not of the same model, the SXL II will copy as many settings as possible. Different gain structures of the amplifiers are considered in advance and will – if possible – be made up for.

The *Force Amp Error* function of the web interface (refer to [section 3.15.8.7](#)) offers a comfortable way to test the combination of SXL II, AX16 and amplifiers, as well as their wiring. Every possible type of defect may be tested.

Split Mode Split Mode allows for the simultaneous operation of amplifiers with or without SXL II data port with an AX16. Every combination or group is possible. Please note that that the amplifiers of a group (7+1, 3+1 or 1+1) have to be of the same type (i.e. low impedance or 100V).

Split Mode may be activated in the web interface of the SXL II on page AX16 (refer to [section 3.15.8.7](#)).

Please mind the followint points:

- Amplifiers without a dataport will be connected to the AX16 using the alive relay. The corresponding DIP switch has to be set to the ON position (refer to [section 3.14.5.2](#)).
- Amplifiers with dataport have to be connected with the appropriate cable. The corresponding DIP switch has to be set to the OFF position (refer to [section 3.14.5.2](#)).
- DIP switch 3 of the AX16 has to be set to the ON position (refer to [section 3.14.5.4](#)).

**Caution**

The 4X/8X cross cabling is not available in Split Mode.

4X/8X Cross Routing If 4- and 8-channel amplifiers are to be connected to an AX16, it is necessary to bear in mind that these amplifiers have only one power supply per 4 channels. In case of a defect it may be therefore necessary to replace not only 2 but 4 channels.

Cross cabling ensures that the defective module (2 channels) is not connected to the same power supply.

If a complete replacement of defective 4- or 8channel is required, the AX16 has to be set to the 3+1 or 1+1 mode. This ensures the availability of at least 4 replacement channels.

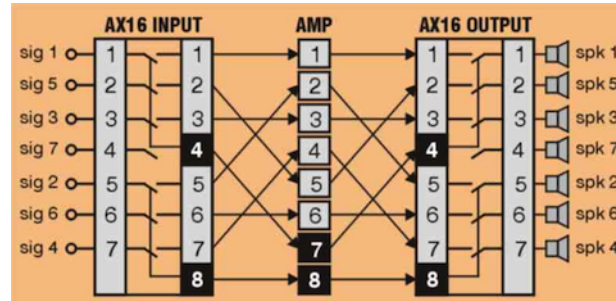

Figure 3.77: SXL II - Cross Routing for 4X/8X Operation

3.15.9.6 Permanent Backup of Operation Modes

After powering up and its initialization, the SXL II configures all connected amplifiers. Thereby, it recalls the stored files of a configuration. There are three different possibilities:

- A. A certain configuration is recalled
- B. The last active configuration is recalled
- C. All last active settings are restored

In case A, the appropriate number 1 to 16 of the configuration is set in the SXL II. The factory default is number 1.

In case B, the configuration 0 is set, as it always contains a copy of the last active configuration (refer to [section 3.15.8.6](#)).

C is an extension of B, as possible changes (e.g. via the Ethernet) may also be restored after recalling a configuration. It needs to be explicitly activated.

The necessary parameter *KeepActCfg* is accessible via Service Mode Level 1 (refer to [section 3.15.7.2](#)). It may be accessed under the *CONFIG* menu. When activated (set value to *ON*), the value of the parameter *DefaultCfg* is automatically set to 0 at the same time.

To test this function, it is recommended to set the *USER LED* in such a way that it indicates the writing of data to the internal flash disk. Set the parameter *LedScr* in the *DIAG* menu to the *KeepActWr* value. Now, if any other parameter is being changed, it will be stored after at least 3 seconds on the internal flash disk. The *USER LED* will indicate this activity by a short illumination.

3.15.10 Software & Files

There are five different categories of data files stored on the internal flash disk or a SD card:

Category	Storage Location
Firmware	Internal Flash Disk
System Settings	Internal Flash Disk
Web Interface	SD Card
Configurations	SD Card
Logbook	Internal Flash Disk

The SD card is of the off-the-shelf type. If the card is missing, it will be indicated in the LCD in short intervals.

The SXL II will operate without the SD card, however, the web interface will not be available and only configuration 0 may be recalled.

3.15.10.1 FTP

The files may be transferred and downloaded from any computer by using FTP (File Transfer Protocol). Any FTP program (e.g. FileZilla) should work. For more advanced users it is also feasible to use the command line.



Caution

The default login is:

Name: sxl

Password: 11111

Do not use caps for the name. The password is five times the figure “one”.

The content of the SD card appears after a successful connection to the FTP program. For safety reasons the files of the internal flash disk will not be viewable.

However, to transfer files to the internal flash disk the data need to be copied to the SD card. After a re-start the SXL II will copy the data automatically to the internal flash disk.

3.15.10.2 Firmware

The firmware of the SXL II is a file with nearly 1 MB and built as follows:

sxl <firmware version> _APP . s19

Example: sxl0465_APP.s19

After connecting to a FTP program, the data files of the SD card will be visible. The new firmware will be automatically copied to the root directory. The transmission will take only a few seconds and is indicated on the LCD of the SXL II.

The SXL II needs to be re-started. This may be comfortably done one of four ways:

- Web Interface - The function is located in the “Misc” menu (refer to [section 3.15.8.8](#))
- Transmission of the “restart.cm” file per FTP. The FTP connection will be automatically closed after the file transfer.

- Press Reset (subjacent on the SXL II frontpanel)
- Switch the SXL II Off and On again.

During a re-start the SXL II will move the new firmware from the SD card to the internal flash disk.

**Caution**

Copying the firmware to the SD card with a card-reader unit and putting the card back into the SXL II will not work! For the installation process an FTP transmission is mandatory.

3.15.10.3 System Settings

The system settings of the SXL II will be stored under the following name:

sxl_usr.s19

Although this system file is stored on the internal flash disk it will be listed in the directory of the SD card for easy access. It can be downloaded per FTP.

If a system file is copied to the SXL II via FTP (for example a backup copy) the file will be directly stored on the internal flash disk.

**Caution**

Copying the firmware to the SD card with a card-reader unit and putting the card back into the SXL II will not work! For the installation process a FTP transmission is mandatory.

3.15.10.4 Web Interface (Files)

The web interface of the SXL II is made up of several files. These files can be found in the subdirectory *Web* of the SD card.

The files may be up- and downloaded via FTP. It is also possible to edit the SD card in a card reader unit with a PC.

**Caution**

It is not necessary to re-start the SXL II after the transmission of one or several files of the web interface is completed. The changes are immediately available after a refresh in the browser.

**Caution**

The update of the firmware of the SXL II may require an update of the web interface to display possible new functions.

3.15.10.5 Configurations

SXL II Configurations Every SXL II configuration is stored in a single file on the SD card. SXL II configurations are identified as follows:

sxl <configuration number> .cfg

The configuration numbers range from 0 to 16.

Example: sxl8.cfg is the SXL II configuration 8.

A .cfg file is only available if the SXL II configuration has been saved under this specific number.



Caution

After its recovery, an SXL II configuration may be called immediately. There is no need to re-start the SXL II.

DSP Configurations Every DSP configuration is saved in a single file on the SD card. DSP configurations are identified as follows:

dsp <configuration number> .cfg

The configuration numbers range from 1 to 50.

Example: dsp23.cfg is the DSP configuration 23

A .cfg file is only available if the SXL II configuration has been saved under this specific number.



Caution

After its recovery, an SXL II configuration may be called immediately. There is no need to re-start the SXL II.

3.15.10.6 Logbook

The SXL II logs every important event on its internal flash disk. The logbook can be exported via the web interface (refer to [section 3.15.8.9](#)).

3.15.11 Amplifier Functions

The following table shows the parameters available on different amplifier models.

If a parameter is not listed/available for an amplifier, the device will also not feature the corresponding hardware parts (e.g. relays, sensors, etc.) for it.

Functions (second column) marked with a # are controllable parameters. All other functions are status values.

		XR DSP	4X/4Xi/4Xe	4X DUAL	8X
Amplifier Functions					
Standby Mode	#	x	x	x	x
Mains Supply		x	x	x	x
Model		x	x	x	x
Firmware Revision		x	x	x	x
Delay Power On	#	x	x	x	x
Online		x	x	x	x
Mode of Operation		x		x	
Number of Channels		x	x	x	x
Alive		x	x	x	x
Channel Functions					
Input Active*	#				
Input Inverted	#	x			
Mute	#	x	x	x	x
Gain	#	x	x	x	x
Clip		x	x	x	x
Protect		x	x	x	x
Input Level		x			
Output Peak Voltage		x	x		
Output Peak Current		x	x		
Temperature		x	x		
Monitor Output Bus A	#	x			
Monitor Output Bus B*	#				
Monitor Output Inverted*	#				
Monitor Gain	#	x			
Output Power		x	x		
Output Load Impedance		x	x		
Load Short		x	x		
Load Open		x	x		
Short Threshold	#	x	x		
Open Threshold	#	x	x		
Paging Input	#	x			
Headroom		x			
Input Sensitivity	#	x			
DSP	#	x			

* These functions were used in former amplifier models

3.15.12 Error Codes

Because of the limited space of the LCD, abbreviations have to be used. Therefore error codes are made up of:

- Device name (2 letters)
- Device number (2 figures)
- Parameters (3 letters)

The individual designations are separated by a point to increase readability. The parameter is abbreviated with its first 3 letters.

The error codes are:

Device Name	Device Number	Error Code	Explanation
NONE	1	NonePar	Non Error-free
AMP	01 to 08	ACStat	ACS Mains supply /fuse
AMP	01 to 08	Online	Onl Communication system bus
AX16	1	ACStat	ACS Mains supply /fuse
AX16	1	Online	Onl Communication system bus
CHAN	01 to 16	Protect	Pro Channel switched off
CHAN	01 to 16	TempT	Tem Temperature above 80°C
CHAN	01 to 16	ShortOut	Sho Impedance below lower limit
CHAN	01 to 16	OpenOut	Ope Impedance above upper limit
CHAN	01 to 16	LoadImp	LIn Impedance could not be measured

Example: A communication error with amplifier ID 5 would show up as AMP.06.Onl.



Caution

Please note that the way of counting the device numbers starts with 1, contrary to the IDs that start with 0.

4 General Technical Information

4.1 Decibel

A decibel is a logarithmic scale commonly used to express differences in signal levels. It is useful in audio because it can express a wide dynamic range with relatively small numbers (or a small movement on a meter), and it more closely matches how we perceive sound.

The measurement quoted in dB describes the ratio between the quantity of two levels, the level being measured and a reference.

The absolute quantity of the signal is not relevant. This means that decibels are always comparing one quantity to another. For example, when we measure gain in dB, we are comparing the output level to the input level.

To describe an absolute value, the reference point must be known. There are different reference points defined.

dBV represents the level compared to 1 Volt RMS. $0 \text{ dBV} = 1 \text{ V}$ with no reference to impedance. dBu represents the level compared to 0.775 Volt RMS on an unloaded, open circuit.

dBm represents the power level compared to 1 mWatt. This is a level compared to 0.775 Volt RMS across a 600 Ohm load impedance.

1 dBV equals +2.2 dBu, +4 dBu equals 1.23 Volt RMS, the reference level of -10 dBV is the equivalent to a level of -7.8 dBu.

Headroom is a measure (usually in dB) of how much higher the peaks of a signal can be compared to the nominal level without clipping. That is, it compares the peak level (in volts RMS) to the nominal level (in volts RMS). The difference between the two (in dB) is the headroom.

4.2 100 V

100V-Systems are referred to as *constant-voltage* distributed audio systems. The constant voltage system is the most economical way to install a multi-speaker sound reinforcement system.

The term *100V system* relates to the maximum output voltage of the amplifier. 100V is the usual voltage in Europe, 70V in the United States. A higher voltage up to 200V can also be used for very long cable runs and higher power requirements.

To generate this high voltage, the amplifier is equipped with a step-up transformer, which transforms the regular output voltage, in the 15 to 30 Volts range, up to the necessary 100V (or 70V respectively).

A 100V-loudspeaker is equipped with a step-down transformer with a relatively high input impedance. The transformer's output impedance matches the included chassis' impedance (usually 8 Ohms). The ratio between the low output impedance of the amplifier and the transformer input impedance of the individual speaker is usually between 1:100 and 1:1000.

Directly proportional to the maximum output power of the amplifier, each 100V amplifier matches a certain minimum impedance than can be connected to this output. It does not matter how the connected impedance is achieved. A large number of smaller speakers (with high input impedance at their step-down transformers) or a small number of larger speakers (with lower impedance) can be connected to the 100V line. Any

combination of different 100V-loudspeakers is possible, as long as the total impedance of the 100V line doesn't fall below the minimum impedance of the amplifier's output.

The real output voltage of the amplifier during the transmission of music or speech is mostly far less than the maximum 100V, proportionally representing the input signal. The term *100V* defines the maximum voltage in the system in the same way as the term +6 dB defines the maximum level for a line signal.

4.3 Measuring Amplifier Power

The output power of an amplifier is most of the time the only criterion to evaluate its performance and quality. For the sake of a quick comparison of different models and manufacturers we tend to forget other important factors like its ability to control EMF (Electro-motoric Force). Unfortunately this comparison at a glance is really misleading as most of the data presented have little or no value at all.

Bittner Audio always provided only one type of output power data: continuous output from 20 Hz to 20 kHz. This sine wave is not representing a real-world music signal, but it makes an excellent statement about the durability of the power supply and the efficiency of the amplifier.

Such a test easily reveals whether a transformer is too weak or that the power supply is converting too much energy into heat. If this is the case, the mains will be quickly overloaded or the amplifier gets so hot that it reaches its thermal capacity.

Continuous power output has been sufficient for many years to determine whether an amplifier is adequately powered for a given application. In fact, other testing procedures have been considered unprofessional and insufficient.

However, new developments require new methods of testing. High power amplifiers with an output of more than 1000 watts per channel are a commodity nowadays. Measuring an amplifier of for example 4000 watts will lead to serious problems if the traditional procedures are applied: driven with a sine wave into its nominal load (i.e. 4 ohms) it will draw more than 6000 watts or 25 A from the supplies. Most mains-fuses will blow during this test and it is most likely illegal to replace the fuse with the next higher value. . .

How can amplifiers of this magnitude be operated from regular mains at all? The answer is rather simple: even highly compressed music material like Rave/Dance or alarm signals are not comparable to a full power continuous output.

Therefore, most manufacturers decided to publish their data according to the following "real-world" testing procedure: the maximum output power of an amplifier will be measured with a 1 kHz sine wave with a 33.3 ms on-time followed by 66.6 ms off-time. This test is closer to music program and will indicate a higher power, however, there will be no excessive draw on the mains, and fuses will stay intact. As a continuous power output 1/8 or 1/3 load is chosen.

Although this is closer to reality it also delivers values that cannot be verified applying the traditional testing procedures: a 2000 watts per channel amplifier tested with a burst signal delivers a continuous power output of approximately 650 watts (1/3 load) or 250 watts (1/8 load).

Unfortunately, it is still not possible to compare the products of different manufacturers. Neither are similar methods applied, as it is not really clear what a burst signal is made of, nor are the conditions known under which the results have been achieved. Therefore, if continuous output power data are available, they are still a good means to evaluate performance and durability. Please keep in mind that professional power amplifiers should be tools that have been designed for untroubled continuous operation to justify the investment.

Bittner Audio will therefore provide all data in the accustomed fashion i.e. continuous output power to demonstrate the capacity and stability of the products. In addition, the output power will also be indicated using the described testing method of a 33.3/66.6 ms burst signal to allow an easier comparison of different models and brands.

However, care should be taken while dimensioning fuses and or uninterrupted power supplies (UPS). In this case we recommend applying the power consumption of 1/8 or in the worst case 1/3 load. This also holds for determining the cooling capacity of air conditioned technical rooms.

For all the described values, including the damping factor at 4 ohms, refer to the technical data tables ([section 5](#)).

4.4 Heat Dissipation and Air Conditioning

The values of heat dissipation, provided by most amplifier manufacturers are normally being used to answer the question, how much cooling of a closed rack is necessary. However, whether costly air conditioning is really necessary cannot be easily answered and may be subject to the following considerations:

- an amplifier is designed to operate normally at about 25°C ambient temperature without additional cooling
- lid or bottom of the amplifier chassis, as well as the side panels may not be removed to ensure a constant and effective flow of air
- good ventilation of the rack is normally sufficient
- air conditioning may be necessary to provide cooling, if the hot air is not being vented from the amplifier rack
- amplifiers generate the most excess heat while being driven between 40 and 60 percent - no matter which amplifier class is being used. Therefore, it is reasonable and sensible to use the heat dissipation values of approximately 1/3 power.

Please note: 1/3 power is a very high value that may occur only in case of an alarm being set off. Therefore, in most applications, good ventilation will be more than enough to provide safe operation.

4.5 Sound Pressure and Amplifier Power

The dynamic range of hearing reaches from a low whisper to the discomforting roar of a jet engine. This range equals a ratio of 1:1024!

Experience shows that large numbers cannot be handled easily. Therefore, a system has been developed to handle these large ratios in easy decibels. This system of number relations may be used to handle both electrical and acoustical values. Please note the following definitions:

Doubling a voltage or a current - for example from 1 to 2 volts - corresponds to an increase of 6 dB. Dividing the same voltage by two will result in a decrease of 6 dB.

Example: If the output level of an amplifier is raised by 18 dB, the actual output voltage is 8 times higher than the original one, and will raise from 2 to 16 volts.

Doubling the power (or loudness) follows a different ratio. An increase from 1 watt to 2 watts represents a raise of 3 dB!

This indicates that an increase of 6 dB represents 4 times the original power (see formulas in [section 4.6.5](#)).

Example: If the output power of an amplifier is increased by 18 dB, it's been raised by a factor of 64 (!) => from 2 to 128 watts for example.

This also indicates that raising the loudness by 1 dB will require 27% more output power. Doubling the loudness (3 dB) will result in 100% more output power.

While selecting an appropriate power amplifier, please note: Doubling the output power of an amplifier increases the loudness (SPL) by 3 dB. Unfortunately, this does not mean, that the impression of loudness is doubled as well. The human ear shows a varying sensitivity over frequency. Therefore, on average, we require 10 dB increase of SPL (loudness) to feel a subjective doubling of the loudness. This, however, will then require 10 times the output power of an amplifier - i.e. a 1000 W amplifier will seem (!) to be only twice as loud as a 100 Watt amp.

4.6 Essentials

4.6.1 Load-to-Power Relation in 100 V Systems

$$\begin{array}{lll} 10 \Omega = 1000 W & 20 \Omega = 500 W & 25 \Omega = 400 W \\ 40 \Omega = 250 W & 50 \Omega = 200 W & 100 \Omega = 100 W \end{array}$$

4.6.2 Crest Factor

The Crest Factor of an amp represents the relation between the peak voltage and the RMS value. It can be taken as a measurement of the quality of the response of an amp.

$$\text{Crest Factor} = \frac{\text{Peak}}{\text{RMS}} = \frac{1}{\sqrt{2}} \times \text{Peak}$$

4.6.3 Resistance - Power

Ohm's Law:

$$U = I \times R \quad I = \frac{U}{R} \quad R = \frac{U}{I}$$

Power:

$$P = I^2 \times R \quad P = \frac{U^2}{R} \quad P = U \times I$$

Resistors in series:

$$R_{total} = R_1 + R_2 + \dots + R_n$$

Resistors parallel:

$$R_{total} = \frac{1}{\frac{1}{R_1} + \frac{1}{R_2} + \dots + \frac{1}{R_n}}$$

4.6.4 Voltages in dBV and dBu

$$\begin{array}{lll} 10 V = & 20 dBV = & 22.2 dBu \\ 1.55 V = & 4.2 dBV = & 6 dBu \\ 1 V = & 0 dBV = & 2.2 dBu \\ 775 mV = & -2.2 dBV = & 0 dBu \\ 316 mV = & -10 dBV = & -7.8 dBu \end{array}$$

4.6.5 "dB"-Relations

$$\text{Voltage: } dB = 20 \log_{10} \frac{U_1}{U_2} \quad \text{Power: } dB = 10 \log_{10} \frac{P_1}{P_2}$$

4.6.6 Conversion of THD to “dB below signal level”

THD %	dB below signal	THD %	dB below signal	THD %	dB below signal
100	0	0.5	-46	0.01	-80
10	-20	0.25	-52	0.005	-86
5	-26	0.1	-60	0.002	-92
1	-40	0.05	-66	0.005	-100

4.6.7 Voltage to Power

Volt	Watt 4 Ω	Watt 8 Ω	Volt	Watt 4 Ω	Watt 8 Ω
63.2	1000	500	20	100	50
44.8	500	250	14.1	50	25
31.6	250	125	10	25	12.5
28.2	200	100	6.3	10	5
22.4	125	62.5	2	1	0.5

5 Technical Data

		Basic				XB				XR				
		200	400	800	1200	400	800	1600	2500	1500	2000	2500	4000	
Channels		2	2	2	2	2	2	2	2	2	2	2	2	
Class		AB	AB	AB	AB	AB	AB	H	H	H	H	H	H	
Burst per Channel 1 kHz	W	8 Ω	100	180	290	500	230	350	570	700	530	590	700	850
		4 Ω	130	250	490	840	360	530	960	1130	880	985	1130	1360
		2 Ω	---	---	---	---	---	---	1250	1570	1220	1340	1570	1950
Output Power per Chan. 20 Hz - 20 kHz 0.1% THD	W	8 Ω	80	125	230	380	170	270	460	570	420	460	570	720
		4 Ω	105	170	330	610	270	410	760	930	680	730	920	1130
		2 Ω	---	---	---	---	---	---	1020	1200	940	1030	1170	1700
Output Power per Chan. 1 kHz / 1% THD	W	8 Ω	85	130	240	400	180	290	490	620	440	490	610	780
		4 Ω	115	180	350	650	290	430	820	1020	740	790	1000	1230
		2 Ω	---	---	---	---	---	---	1120	1310	1020	1130	1290	1810
Output Power bridged 20 Hz - 20 kHz 0.1% THD	W	16 Ω	160	250	460	760	340	540	890	1120	840	920	1040	1440
		8 Ω	210	340	660	1220	540	800	1500	1850	1360	1460	1840	2220
		4 Ω	---	---	---	---	---	---	2000	2400	1880	2060	2340	3300
Frequency Response Full Power	dB	20 Hz	0	0	0	0	0	0	0	0	0	0	0	0
		20 kHz	-0.3	-0.3	-0.3	-0.3	-0.3	-0.3	-0.3	-0.3	-0.5	-0.5	-0.5	-0.5
THD 20 Hz - 20 kHz 10 dB below Full Power	%	<	0.06	0.05	0.06	0.02	0.03	0.03	0.01	0.01	0.02	0.02	0.02	0.03
THD 1 kHz Full Power	%	<	0.08	0.06	0.08	0.05	0.05	0.05	0.03	0.03	0.03	0.03	0.03	0.04
Signal-to-Noise Ratio 20 Hz - 20 kHz	dB	>	102	103	103	103	103	105	103	103	103	103	103	103
Channel Separation	dB	>	85	85	85	85	85	85	80	80	80	80	80	80
Input Sensitivity	dBu		-1	0	+3	+6	+2	+3	+6	+6	+6	+6	+6	+6
Input Clipping	dBu		22	22	22	22	22	22	22	22	14	14	14	14
Input Impedance	kΩ		20	20	20	20	20	20	20	12	12	12	12	12
Voltage Gain	dB		28.8	31.4	34.1	36.4	32.4	34.2	30.5	30.5	30.5	30.5	30.5	30.5
Damping Factor		4 Ω	400	400	400	500	500	500	750	900	750	900	900	1200
Cooling Fans (temperature controlled)	front		0	0	0	0	0	0	0	2	2	2	2	2
	back		2	2	2	2	2	2	2	2	2	2	2	2
Idle Current	A		0.1	0.1	0.2	0.2	0.1	0.2	0.4	0.4	0.5	0.5	0.5	0.5
Power Consumption 1/8 Load (Speech)	A	8 Ω	0.7	1.1	1.8	2.8	1.4	2.0	2.5	3.0	2.1	2.5	3.0	3.3
		4 Ω	1.0	1.6	2.8	4.5	1.9	3.2	4.0	4.7	3.3	4.0	4.8	5.2
		2 Ω	---	---	---	---	---	---	6.0	6.7	5.1	6.1	7.0	7.8
Power Consumption 1/3 Load (compressed Music)	A	8 Ω	1.0	1.6	2.7	4.2	2.0	2.9	4.9	6.0	4.5	4.9	5.9	7.7
		4 Ω	1.5	2.4	4.1	7.0	2.8	4.7	7.9	9.1	7.3	7.9	9.3	12.3
		2 Ω	---	---	---	---	---	---	10.5	12.6	10.1	10.7	11.2	16.7
Power Consumption Full Power	A	8 Ω	1.6	2.5	4.2	6.8	3.2	5.0	9.0	10.7	8.2	8.8	10.7	13.5
		4 Ω	2.4	3.7	5.6	11.0	5.1	7.7	15.1	17.4	13.7	14.6	17.5	22.2
		2 Ω	---	---	---	---	---	---	23.0	27.2	21.3	23.0	27.6	>30
Heat Dissipation (Idle)	W*		12	17	22	22	15	20	40	40	55	55	55	55
Heat Dissipation 1/8 Load (Speech)	W*	8 Ω	105	160	255	365	165	260	210	300	170	220	270	280
		4 Ω	150	245	425	660	260	450	380	470	290	375	460	500
		2 Ω	---	---	---	---	---	---	630	730	490	640	730	830
Heat Dissipation 1/3 Load (compressed Music)	W*	8 Ω	130	210	330	400	210	340	400	450	410	420	480	700
		4 Ω	230	340	600	770	350	610	690	790	690	700	825	1200
		2 Ω	---	---	---	---	---	---	1000	1160	930	940	950	1700
Heat Dissipation Full Power	W*	8 Ω	150	230	340	420	220	340	440	490	420	440	520	680
		4 Ω	280	410	640	800	360	650	790	1000	750	780	950	1290
		2 Ω	---	---	---	---	---	---	1620	2000	1490	1600	2040	---
DSP				no				no			yes			
SXL Dataport				no				no			I ² C and RS485			
Remote Power On				no				yes			yes			
Alive Contacts				no				1			1			
Backup Power		24 VDC		no				no			no			
Height	RU		2	2	2	2	2	2	2	2	2	2	2	
Depth	mm		320	320	320	454	382	382	454	454	454	454	454	
Weight (net)	kg		10	12	13	15	12	13	13	13.5	14	14	14	
Power Requirements	V		210-240				210-240				210-240			
	Hz		50-60				50-60				50-60			

* 1 Watt = 3.412 BTU/Std. = 3600 Joule/Std.

All specifications subject to change without notice. All specs under www.bittner-audio.com

Figure 5.1: Technical Data - Low Impedance Amplifiers

			4Xi / 4Xe		4X DUAL		8X		
			1200	2000	400	600	100	200	400
Channels			4	4	4	4	8	8	8
Class			H	H	AB	AB	AB	AB	AB
Burst per Channel 1 kHz	W	8 Ω	630	820	290	380	100	180	270
		4 Ω	1000	1300	450	630	130	250	490
		2 Ω	1400	2000	---	---	---	---	---
Output Power per Chan. 20 Hz - 20 kHz 0.1% THD	W	8 Ω	540	700	230	290	80	120	190
		4 Ω	890	1160	310	370	100	180	330
		2 Ω	1150	1650	---	---	---	---	---
Output Power per Chan. 1 kHz / 1% THD	W	8 Ω	600	770	240	310	90	130	200
		4 Ω	980	1280	320	420	110	200	350
		2 Ω	1260	1820	---	---	---	---	---
Output Power bridged 20 Hz - 20 kHz 0.1% THD	W	16 Ω	1030	1350	460	600	160	260	360
		8 Ω	1710	2160	620	820	200	320	460
		4 Ω	2270	3140	---	---	---	---	---
Frequency Response Full Power	dB	20 Hz	0	0	0	0	0	0	0
		20 kHz	-0.5	-0.5	-0.2	-0.2	-0.3	-0.3	-0.3
THD 20 Hz - 20 kHz 10 dB below Full Power	%	<	0.02	0.02	0.03	0.03	0.02	0.03	0.03
THD 1 kHz Full Power	%	<	0.03	0.03	0.04	0.04	0.03	0.04	0.04
Signal-to-Noise Ratio 20 Hz - 20 kHz	dB	>	100	100	103	103	101	103	103
Channel Separation	dB	>	75	75	80	80	85	85	85
Input Sensitivity	dBu		+4	+4	+6	+6	-1	0	+2
Input Clipping	dBu		20	20	21	21	22	22	22
Input Impedance	kΩ		20	20	20	20	20	20	20
Voltage Gain	dB		30.5	30.5	31.4	32.4	28.8	31.4	34.1
Damping Factor		4 Ω	700	700	800	800	400	400	400
Cooling Fans (temperature controlled)	front		2	2	2	2	0	2	2
	back		2	2	2	2	2	2	2
Idle Current	A		0.7	0.7	0.3	0.4	0.5	0.3	0.3
Power Consumption 1/8 Load (Speech)	A	8 Ω	5.5	6.0	2.1	2.6	2.9	4.4	7.0
		4 Ω	8.5	9.0	2.9	3.8	4.2	6.4	11.0
		2 Ω	11.0	12.0	---	---	---	---	---
Power Consumption 1/3 Load (compressed Music)	A	8 Ω	11.0	14.0	4.9	6.3	4.4	6.5	10.2
		4 Ω	17.5	23.0	6.9	8.9	6.4	9.5	16.3
		2 Ω	21.5	26.5	---	---	---	---	---
Power Consumption Full Power	A	8 Ω	19.0	23.0	8.4	11.0	6.7	9.5	14.7
		4 Ω	>30	>30	11.9	16.0	10.0	13.9	21.1
		2 Ω	>30	>30	---	---	---	---	---
Heat Dissipation (Idle)	W*		80	80	50	50	50	58	74
Heat Dissipation 1/8 Load (Speech)	W*	8 Ω	460	500	230	300	420	630	1060
		4 Ω	800	850	360	500	650	1010	1700
		2 Ω	1200	1300	---	---	---	---	---
Heat Dissipation 1/3 Load (compressed Music)	W*	8 Ω	950	1300	490	710	560	810	1300
		4 Ω	1650	2300	790	1160	900	1350	2200
		2 Ω	1900	2750	---	---	---	---	---
Heat Dissipation Full Power	W*	8 Ω	1000	1350	670	900	560	850	1390
		4 Ω	---	---	1150	1660	1070	1480	2320
		2 Ω	---	---	---	---	---	---	---
DSP			no		no		no		
SXL Dataport			RS485		I2C		I2C		
Remote Power On			yes		yes		yes		
Alive Contacts			2		no		4		
Backup Power		24 VDC	no		no		no		
Height	RU		2	2	2	2	2	2	
Depth	mm		454	454	454	454	454	454	
Weight (net)	kg		15	16	19	20	18	20	22
Power Requirements	V		210-240		210-240		210-240		
	Hz		50-60		50-60		50-60		

* 1 Watt = 3.412 BTU/Std. = 3600 Joule/Std.

 All specifications subject to change without notice. All specs under www.bittner-audio.com
Figure 5.2: Technical Data - Multichannel Amplifiers

		XV					XV DC		2DXV		4DXV		
		200	400	600	1000	1600	500	1000	300	500	250	500	
Channels		2	2	2	2	2	2	2	2	2	4	4	
Class		AB	AB	AB	AB	AB	H	H	D	D	D	D	
Output Power per Chan.	W	100 V	100	200	300	500	800	250	500	300	500	250	500
Frequency Response 100V	dB	20 Hz	0	0	0	0	0	0	0	-0.6	-0.6	0	0
		20 kHz	-0.3	-0.3	-0.3	-0.3	-0.3	-0.3	-0.3	-1.0	-1.3	-0.3	-0.3
Frequency Response 70V	dB	20 Hz	---	---	---	---	---	---	---	-0.4	-0.4	---	---
		20 kHz	---	---	---	---	---	---	---	-1.5	-2.2	---	---
THD 1 kHz Full Power	%	<	0.07	0.06	0.06	0.06	0.07	0.03	0.03	0.15	0.15	0.03	0.03
Signal-to-Noise Ratio 20 Hz - 20 kHz	dB	>	101	103	103	105	107	101	101	96	96	100	100
Channel Separation	dB	>	75	75	75	70	70	65	65	75	75	96	92
Input Sensitivity	dBu		-1	0	+2	+3	+6	+6	0	0	0	0	0
Input Clipping	dBu		22	22	22	22	22	22	22	21	21	21	21
Input Impedance	kΩ		20	20	20	20	20	20	20	14	14	12	12
Voltage Gain	dB		42	42	42	42	42	42	42	42	42	42	42
Cooling Fans (temperature controlled)	front		0	0	0	0	0	1	1	0	0	3	3
	back		2	2	2	2	3	2	2	1	1	1	1
Idle Current	A	230 VAC	0.1	0.1	0.1	0.1	0.1	0.2	0.2	0.3	0.3	0.5	0.5
		24 VDC	---	---	---	---	---	1.5	1.7	1.6	1.6	2.9	3.0
Power Consumption 1/8 Load (Speech)	A	100 V	1.1	1.9	3.1	3.9	5.9	1.4	3.0	0.9	1.3	1.8	2.8
		24 VDC	---	---	---	---	---	8.7	19.1	5.5	8.8	11.8	18.6
Power Consumption 1/3 Load (compr. Music)	A	100 V	1.6	2.8	4.7	5.8	9.0	3.2	4.7	1.8	3.0	3.3	6.0
		24 VDC	---	---	---	---	---	21.2	39.0	12.0	20.2	22.8	41.6
Power Consumption Full Power	A	100 V	2.5	4.5	7.4	9.3	14.1	6.0	12.4	4.7	8.0	7.9	15.5
		24 VDC	---	---	---	---	---	38.6	84.0	33.0	53.0	49.7	78.6
Heat Dissipation (Idle)	W*		13	16	18	19	19	22	25	39	39	73	76
Heat Dissipation 1/8 Load (Speech)	W*	100 V	175	285	500	640	990	165	365	55	90	170	215
Heat Dissipation 1/3 Load (compr. Music)	W*	100 V	240	390	670	820	1430	355	430	85	150	220	330
Heat Dissipation Full Power	W*	100 V	310	450	780	970	1780	490	1070	160	300	300	580
DSP			no					no		no		no	
SXL Dataport			no					no		no		no	
Remote Power On			yes					yes		yes		yes	
Alive Contacts			1					1		3		2	
Backup Power		24 VDC	no					yes		yes		yes	
Height	RU		2	2	2	2	2	2	2	2	2	2	2
Depth	mm		454	454	454	454	454	454	454	302	302	454	454
Weight (net)	kg		19	20	18	20	22	15	18	13	13	14	14
Power Requirements	V		210-240					210-240		210-240		210-240	
	Hz		50-60					50-60		50-60		50-60	

* 1 Watt = 3.412 BTU/Std. = 3600 Joule/Std.

All specifications subject to change without notice. All specs under www.bittner-audio.com**Figure 5.3:** Technical Data - 100V/70V Amplifiers

6 Troubleshooting

Problem: The unit cannot be switched on.

- Cause: Power cord not connected properly. Mains power not available. Main power fuses defect.
- Solution: Check the power cords and the mains power supply. Check the main power fuses at the back panel of the amplifier.

Problem: Amplifier is switched on, audio signal supplied but LED SIGNAL doesn't illuminate.

- Cause: Audio input cable defect or not properly connected.
- Solution: Check the audio signal cables and the signal source.

Problem: SIGNAL LED is on, but no sound.

- Cause: Speaker cables are not connected properly, or loudspeaker defect. Speaker cables connected to the wrong channel, or polarity in SPEAKON connector not according to the norm.
- Solution: Check the speaker cables and the loudspeakers.

Problem: No communication to the control computer.

- Cause: Wiring incorrect.
- Solution: Check wiring in general, check polarity of the data cables, check additional ground connection for the data cables between devices.

Problem: No communication to the control computer, or to a single amplifier.

- Cause: Invalid address is set.
- Solution: Check DIP-Switches on the back panel of the SXL, address 0 to 15 possible in one system, same address in one system will cause failure.

List of Figures

1.1	Lightning Symbol	7
2.1	Backup Power Connector	10
2.2	Remote Switching PHOENIX Connector	11
2.3	Amp Status	12
2.4	Analog Level Controls	13
2.5	Digital Level Controls (with stop)	13
2.6	Digital Level Controls (endless)	13
2.7	XLR Connector	14
2.8	TRS Jack	15
2.9	Wiring in Bridge Mode with no mode switch	17
2.10	Alive Contact	18
2.11	Multifunction Connector	18
2.12	I ² C Data Port	20
2.13	RS-485 Data Port	20
2.14	RS-485 Connector	20
3.1	BASIC Series - Front View	25
3.2	BASIC Series - Rear View	25
3.3	XB Series - Front View	27
3.4	XB Series - Rear View	27
3.5	XB Series - Jumper and Fuses	28
3.6	XR Series - Front View	30
3.7	XR Series - Rear Viwe	30
3.8	NA-1	31
3.9	XR Series - Emergency Paging Bus and Monitor Bus	33
3.10	4X Series - Front View	35
3.11	4X Series - Rear View	35
3.12	4X Series - Jumper and Fuses	36
3.13	4Xi Series - Front View	38
3.14	4Xi Series - Rear View	38
3.15	4Xe Series - Front View	39
3.16	4Xe Series - Rear View	39
3.17	4Xi/4Xe Series - Fuses	40
3.18	4Xi/4Xe Series - Dante™ Ports	42
3.19	4X DUAL Series - Front View	44
3.20	4X DUAL Series - Rear View	44
3.21	4X DUAL Series - Jumper and Fuses	45
3.22	8X Series - Front View	47
3.23	8X Series - Rear View	47
3.24	8X Series - Jumper and Fuses	48
3.25	XV Series - Front View	50
3.26	XV Series - Rear View	50
3.27	XV Series - Jumper and Fuses	51
3.28	XV DC Series - Front View	53
3.29	XV DC Series - Rear View	53
3.30	XV DC Series - DIP Switches	54
3.31	2DXV Series - Front View	56
3.32	2DXV Series - Back View	56
3.33	4DXV Series - Front View	59
3.34	4DXV Series - Rear View	59
3.35	XT Transformer - Connection Wires and Sticker	60
3.36	8XT Series - Front View	61
3.37	8XT Series - Rear View	61
3.38	AX16 - Block Diagram	62
3.39	AX16 - Front View	64
3.40	AX16 - Rear View	64
3.41	AX16 - LED Indicators Frontside	65

3.42 AX16 - LED Indicators Backside	65
3.43 AX16 - DIP Switches	65
3.44 AX16 - Switching Modes	66
3.45 AX16 - Signal Inputs	67
3.46 AX16 - Amplifier Inputs	68
3.47 AX16 - Amplifier Outputs	68
3.48 AX16 - Loudspeaker Outputs	68
3.49 AX16 - Alive Contact Inputs	68
3.50 AX16 - Digital Level Controls	69
3.51 AX16 - Alive Contacts	69
3.52 AX16 - Mode 7+1 with Alive Contacts	71
3.53 AX16 - Mode 3+1 with SXL II and Alive Contacts	72
3.54 AX16 - Mode 3+1 with 4 Channel Amplifiers and Alive Contacts	73
3.55 SXL II - Front View	75
3.56 SXL II - Rear View	75
3.57 SXL II - Integration in an Ethernet network	76
3.58 SXL II - Ethernet Connector	76
3.59 SXL II - I ² C System Bus Cable	77
3.60 SXL II - LED Indicators Front Side	78
3.61 SXL II - LED Indicators Rear Side	79
3.62 SXL II - Logical Inputs	79
3.63 SXL II - Signalization Relay Outputs of the Error Matrix	80
3.64 SXL II - GPR Relay Outputs	80
3.65 SXL II - Signal Generator Output	80
3.66 SXL II - LCD and Front Panel Control	81
3.67 SXL II - Web Interface	83
3.68 SXL II - Web Interface: Header	84
3.69 SXL II - Web Interface: Expand Arrows	85
3.70 SXL II - Web Interface: Copy of DSP Settings	86
3.71 SXL II - Web Interface: Signal Generator	86
3.72 SXL II - Web Interface: Monitored Channels	87
3.73 SXL II - Web Interface: Load Impedance Window	87
3.74 SXL II - Web Interface: Error Matrix	87
3.75 SXL II - Web Interface: Status Information	89
3.76 SXL II - Line Monitoring	94
3.77 SXL II - Cross Routing for 4X/8X Operation	96
5.1 Technical Data - Low Impedance Amplifiers	108
5.2 Technical Data - Multichannel Amplifiers	109
5.3 Technical Data - 100V/70V Amplifiers	110